

# Ninja ZX-4R

## Motorcycle

---

# OWNER'S MANUAL

---

 Read this manual carefully. It contains safety information.

---

---



 **WARNING**

**Operating, servicing and maintaining a passenger vehicle or off-road vehicle can expose you to chemicals including engine exhaust, carbon monoxide, phthalates, and lead, which are known to the State of California to cause cancer and birth defects or other reproductive harm. To minimize exposure, avoid breathing exhaust, do not idle the engine except as necessary, service your vehicle in a well-ventilated area and wear gloves or wash your hands frequently when servicing your vehicle. For more information go to [www.P65warnings.ca.gov/passenger-vehicle](http://www.P65warnings.ca.gov/passenger-vehicle).**

For more information about safe riding (Movie and/or Booklets) on your Kawasaki products, please scan this QR with your camera equipped mobile device or visit this website at <https://www.kawasaki.com/en-us/owner-center/safety-resources>





# Quick Reference Guide

This Quick Reference Guide will assist you in finding the information you're looking for.

**SAFETY INFORMATION**

**GENERAL INFORMATION**

**HOW TO RIDE THE MOTORCYCLE**

**MAINTENANCE AND ADJUSTMENT**

**APPENDIX**

**MAINTENANCE RECORD**

A Table of Contents is included after the Foreword.

Whenever you see the symbols shown below, heed their instructions! Always follow safe operating and maintenance practices.

 **DANGER**

**DANGER** indicates a hazardous situation which, if not avoided, will result in death or serious injury.

 **WARNING**

**WARNING** indicates a hazardous situation which, if not avoided, could result in death or serious injury.

***NOTICE***

**NOTICE** is used to address practices not related to personal injury.

**NOTE**

- *NOTE* indicates information that may help or guide you in the operation or service of the vehicle.

## ***NOTICE***

**THIS PRODUCT HAS BEEN  
MANUFACTURED FOR USE IN A  
REASONABLE AND PRUDENT  
MANNER BY A QUALIFIED OP-  
ERATOR AND AS A VEHICLE  
ONLY.**

## Foreword

Congratulations on your purchase of a new Kawasaki motorcycle. Your new motorcycle is the product of Kawasaki's advanced engineering, exhaustive testing, and continuous striving for superior reliability, safety and performance.

**Please read this Owner's Manual carefully before riding** so that you will be thoroughly familiar with the proper operation of your motorcycle's controls, its features, capabilities, and limitations. This manual offers many safe riding tips, but its purpose is not to provide instruction in all the techniques and skills required to ride a motorcycle safely. Kawasaki strongly recommends that all operators of this vehicle enroll in a motorcycle rider training program to attain awareness of the mental and physical requirements necessary for safe motorcycle operation.

To ensure a long, trouble-free life for your motorcycle, give it the proper care and maintenance described in this manual. For those who would like more detailed information on their Kawasaki Motorcycle, a Service Manual is available for purchase from any authorized Kawasaki motorcycle dealer. The Service Manual contains detailed disassembly and maintenance information. Those who plan to do their own work should, of course, be competent mechanics and possess the special tools described in the Service Manual.

Keep this Owner's Manual aboard your motorcycle at all times so that you can refer to it whenever you need information.



This manual should be considered a permanent part of the motorcycle and should remain with the motorcycle when it is sold.

All rights reserved. No part of this publication may be reproduced without our prior written permission.

This publication includes the latest information available at the time of printing. However, there may be minor differences between the actual product and illustrations and text in this manual.

All products are subject to change without prior notice or obligation. Any updated information is available in the on-line Owner's Manual on Kawasaki's website.

**[Owner's Manual]**



**KAWASAKI MOTORS, LTD.**

# Emission Control Information

To protect the environment in which we all live, Kawasaki has incorporated crankcase emission (1) and exhaust emission (2) control systems in compliance with applicable regulations of the United States Environmental Protection Agency and California Air Resources Board. Additionally, Kawasaki has incorporated an evaporative emission control system (3) in compliance with applicable regulations of the United States Environmental Protection Agency and California Air Resources Board.

## **1. Crankcase Emission Control System**

This system eliminates the release of crankcase vapors into the atmosphere. Instead, the vapors are routed through an oil separator to the intake side of the engine. While the engine is operating, the vapors are drawn into the combustion chamber, where they are burned along with the fuel and air supplied by the fuel injection system.

## **2. Exhaust Emission Control System**

This system reduces the amount of pollutants discharged into the atmosphere by the exhaust of this motorcycle. The fuel, ignition and exhaust systems of this motorcycle have been carefully designed and constructed to ensure an efficient engine with low exhaust pollutant levels. The exhaust system of this model motorcycle includes a catalytic converter system.

### **3. Evaporative Emission Control System**

The evaporative emission control system for this vehicle consists of low permeation fuel hoses and fuel tank.

### **3. Evaporative Emission Control System (California)**

Vapors caused by fuel evaporation in the fuel system are not vented into the atmosphere. Instead, fuel vapors are routed into the running engine to be burned, or stored in a canister when the engine is stopped.

### **High Altitude Performance Adjustment Information**

High Altitude adjustment is not required.

---

## Maintenance and Warranty

---

Proper maintenance is necessary to ensure that your motorcycle will continue to have low emission levels. This Owner's Manual contains those maintenance recommendations for your motorcycle. Those items identified by the Periodic Maintenance Chart are necessary to ensure compliance with the applicable standards.

As the owner of this motorcycle, you have the responsibility to make sure that the recommended maintenance is carried out according to the instructions in this Owner's Manual at your own expense.

The Kawasaki Limited Emission Control System Warranty requires that you return your motorcycle to an authorized Kawasaki dealer for remedy under warranty. Please read the warranty carefully, and keep it valid by complying with the owner's obligations it contains.

You should keep a maintenance record for your motorcycle. To assist you in keeping this record, we have provided space in the MAINTENANCE RECORD chapter where an authorized Kawasaki dealer, or someone equally competent, can record the maintenance. You should also retain copies of maintenance work orders, bills, etc., as verification of this maintenance.

---

## **Tampering With Noise Control System Prohibited**

---

Federal law prohibits the following acts or the causing thereof: (1) the removal or rendering inoperative by any person other than for purposes of maintenance, repair, or replacement, of any device or element of design incorporated into any new vehicle for the purpose of noise control prior to its sale or delivery to the ultimate purchaser or while it is in use, or (2) the use of the vehicle after such device or element of design has been removed or rendered inoperative by any person.

Among those acts presumed to constitute tampering are the acts listed below:

- \* Replacement of the original exhaust system or muffler with a component not in compliance with Federal regulations.
- \* Removal of the muffler(s) or any internal portion of the muffler(s).
- \* Removal of the air box or air box cover.
- \* Modifications to the muffler(s) or air intake system by cutting, drilling, or other means if such modifications result in increased noise levels.

---

## TABLE OF CONTENTS

---

<b>SAFETY INFORMATION</b> .....	15	<b>GENERAL INFORMATION</b> .....	27
Read Owner's Manual .....	15	Specifications .....	27
Training .....	15	Serial Number Locations .....	31
Daily Checks and Periodic Maintenance .....	15	Location of Labels .....	32
Loading and Accessories Information .....	16	Location of Parts .....	38
Passenger .....	17	Meter Instruments .....	41
Baggage and Luggage .....	18	Indicators .....	45
Accessories .....	18	Speedometer/Tachometer .....	52
Other Load .....	19	Features .....	53
If You are Involved in an Accident....	20	Control Buttons .....	59
Safe Operation .....	20	Multifunction Display .....	60
Carbon Monoxide Hazard .....	20	Multifunction Display Resetting....	64
Fueling .....	21	Menu Mode .....	65
Never Ride with Drugs or Alcohol.	21	Stopwatch .....	86
Protective Gear and Clothing .....	21	Keys .....	89
Safe Riding Techniques .....	22	Ignition Switch/Steering Lock .....	90
Additional Considerations for High Speed Operation .....	25	Right Handlebar Switches .....	92
		Left Handlebar Switches .....	93
		Brake Lever Adjuster .....	95
		Clutch Lever Adjuster .....	96

Fuel .....	97
Fuel Requirements .....	97
Filling the Tank.....	100
Side Stand .....	103
Seats .....	103
Tie Hooks .....	106
Helmet Lock .....	106
Tool Kit .....	107
Electrical Accessory Connectors.....	107
Air Cleaner Intake .....	108
<b>HOW TO RIDE THE MOTORCYCLE .</b>	<b>110</b>
Break-In .....	110
Starting the Engine .....	111
Moving Off.....	113
Shifting Gears .....	114
Braking .....	116
ABS .....	117
Stopping the Engine.....	119
Stopping the Motorcycle in an Emergency .....	120
Parking .....	121
Integrated Riding Modes .....	122
KTRC .....	127

Power Mode .....	129
KQS .....	130
<b>MAINTENANCE AND ADJUSTMENT</b>	<b>132</b>
Daily Checks .....	134
Periodic Maintenance.....	137
Engine Oil .....	142
Coolant.....	145
Air Cleaner .....	148
Throttle Control System .....	149
Idle Speed .....	149
Clutch.....	150
Drive Chain .....	151
Brakes.....	156
Brake Light Switches.....	158
Suspension System .....	160
Front Fork .....	160
Rear Shock Absorber .....	161
Setting Tables .....	164
Wheels .....	166
Battery.....	170
Headlight.....	174
Fuses .....	175
General Lubrication.....	177

Cleaning .....	177
General Precautions .....	177
Where to be Careful .....	182
Washing Your Vehicle .....	182
<b>APPENDIX</b> .....	184
Storage .....	184
Troubleshooting Guide .....	187
Your Warranty/Owner Satisfaction ...	188

Reporting Safety Defects .....	194
Environmental Protection .....	195
Location of DFI System Diagnostic Connector .....	195
Vehicle Data Recordings .....	196
Event Data Recorder .....	197
<b>MAINTENANCE RECORD</b> .....	199



---

# SAFETY INFORMATION

---

## Read Owner's Manual

Read this Owner's Manual carefully before riding so that you will be thoroughly familiar with the proper operation of your motorcycle's controls, its features, capabilities, and limitations. This manual offers many safe riding tips, but its purpose is not to provide instruction in all of the techniques and skills required to ride a motorcycle safely.

## Training

Kawasaki strongly recommends that all operators of this vehicle complete a suitable motorcycle rider training program to learn the proper skills and techniques necessary for safe motorcycle operation.

## Daily Checks and Periodic Maintenance

It is important to keep your motorcycle properly maintained and in safe riding condition. Inspect your motorcycle before every ride and carry out all periodic maintenance. See the Daily Checks section and the Periodic Maintenance section in the MAINTENANCE AND ADJUSTMENT chapter for more information.



### **WARNING**

**Failure to perform these checks or to correct a problem before operation may result in serious damage or an accident. Always perform daily checks before operation.**

## 16 SAFETY INFORMATION

To ensure your motorcycle is serviced using the latest servicing information, it is recommended that an authorized Kawasaki Dealer performs the periodic maintenance as directed in the Owner's Manual.

If you notice any irregular operating condition, have your motorcycle thoroughly checked at an authorized Kawasaki dealer as soon as possible.

### Loading and Accessories Information

#### **WARNING**

**Incorrect loading, improper installation or use of accessories or modification of your motorcycle may result in an unsafe riding condition. Before you ride the motorcycle, make sure it is not overloaded and that you have followed these instructions.**

#### **Maximum Load**

Weight of rider, passenger, baggage, and accessories must not exceed 180 kg (397 lb).

With the exception of genuine Kawasaki Parts and Accessories, Kawasaki has no control over the design or application of accessories. In some cases, improper installation

or use of accessories, or motorcycle modification, will void the motorcycle warranty; can negatively affect performance, stability and safety; and can even be illegal.

In selecting and using accessories, and in loading the motorcycle, you are personally responsible for your own safety and the safety of other persons involved.

### NOTE

○ *Kawasaki Parts and Accessories have been specially designed for use on Kawasaki motorcycles. We strongly recommend that all parts and accessories you add to your motorcycle be genuine Kawasaki components.*

Because a motorcycle is sensitive to changes in weight and aerodynamic forces, you must take extreme care in carrying cargo, passengers and/or in

fitting additional accessories. The following general guidelines have been prepared to assist you in making your determinations.

---

### Passenger

---

1. Never carry more than one passenger.
2. The passenger should only sit on the pillion.
3. Any passenger should be thoroughly familiar with motorcycle operation. The passenger can affect control of the motorcycle by improper positioning during cornering and sudden movements. It is important that the passenger sits still while the motorcycle is in motion and not interfere with the operation of the motorcycle. Do not carry animals on your motorcycle.

## 18 SAFETY INFORMATION

4. Do not carry passengers unless passenger footpegs are installed. Instruct any passenger before riding to keep his or her feet on the passenger footpegs and hold on to the operator or seat strap. Do not carry a passenger unless he or she is tall enough to reach the footpegs with their feet.

---

### Baggage and Luggage

---

1. All baggage should be carried as low as possible to reduce the effect on the motorcycle's center of gravity. Baggage weight should also be distributed equally on both sides of the motorcycle. Avoid carrying baggage that extends beyond the rear of the motorcycle.
2. Baggage should be securely attached. Make sure that the baggage

will not move around while you are riding. Recheck baggage security as often as possible (not while the motorcycle is in motion) and adjust as necessary.

3. Do not carry heavy or bulky items on a luggage rack. It is designed for light items, and overloading can affect handling due to changes in weight distribution and aerodynamic forces.

---

### Accessories

---

1. Do not install accessories or carry baggage that impairs the performance of the motorcycle. Make sure that you have not adversely affected any lighting components, road clearance, banking capability (i.e., lean angle), control operation, wheel travel, front fork movement,

or any other aspects of the motorcycle's operation.

2. Weight attached to the handlebar or front fork will increase the mass of the steering assembly and can result in an unsafe riding condition.
3. Fairings, windshields, backrests, and other large items have the capability of adversely affecting stability and handling of the motorcycle, not only due to their weight, but also due to the aerodynamic force acting on these surfaces while the motorcycle is in operation. Poorly designed or installed items can result in an unsafe riding condition. If lugs are provided on the swingarm to attach accessory rear stand adapters, always remove the rear stand adapters before riding or sitting on the machine to prevent possible damage to the muffler or swingarm.

---

## Other Load

---

1. This motorcycle is not intended to be equipped with a sidecar or to be used to tow any trailers or other vehicles. Kawasaki does not manufacture sidecars or trailers for motorcycles and cannot predict the effects of such accessories on handling or stability, but can only warn that the effects can be adverse and that Kawasaki cannot assume responsibility for the results of such unintended use of the motorcycle.
2. Furthermore, any adverse effects on motorcycle components caused by the use of such accessories will not be remedied under warranty.

## 20 SAFETY INFORMATION

### If You are Involved in an Accident

Make sure of your own safety first. Determine the severity of any injuries and call for emergency assistance if needed. Always follow applicable laws and regulations if any other person, vehicle or property is involved.

Do not attempt to continue riding without first evaluating your motorcycle's condition. Inspect for fluid leaks, check critical nuts and bolts, and check the handlebars, control levers, brakes, and wheels for damage and proper function. Ride slowly and cautiously - your motorcycle may have suffered damage that is not immediately apparent. Have your motorcycle thoroughly checked at a Kawasaki dealer as soon as possible.

### Safe Operation

The following should be carefully observed for safe and effective vehicle operation.

---

#### Carbon Monoxide Hazard

---

#### **DANGER**

**Exhaust gas contains carbon monoxide, a colorless, odorless poisonous gas. Inhaling carbon monoxide can cause serious brain injury or death. DO NOT run the engine in enclosed areas. Operate only in a well-ventilated area.**

---

## Fueling

---

 **WARNING**

**Gasoline is extremely flammable and can be explosive under certain conditions.**

**To avoid a possible fire or explosion, turn the ignition switch off. Do not smoke. Make sure the area is well ventilated and free from any source of flame or sparks; this includes any appliance with a pilot light.**

---

## Never Ride with Drugs or Alcohol

---

Alcohol and drugs impair your judgment and reaction time. Never consume alcohol or drugs before or while riding motorcycles.

---

## Protective Gear and Clothing

---

### *Helmet*

Kawasaki strongly recommends both the operator and passenger wear a DOT-approved helmet even if this is not a legal requirement.

- Make sure that your helmet fits correctly and is properly fastened.
- Choose a motorcycle helmet that meets DOT safety standards. Ask your motorcycle dealer to advise you if necessary.

## 22 SAFETY INFORMATION

### ***Eye Protection***

Always use eye protection. If your helmet does not have a visor installed, wear goggles.

### ***Gloves***

Wear gloves which have suitable protection for your hands, especially against abrasion.

### ***Clothing***

Wear the riding wear which have protectors for each parts of the body (chest, shoulders, back, elbows and knees, etc.) as much as possible, or wear protectors for them.

- Always wear a long-sleeved jacket and long trousers which are abrasion resistant and keep you warm.
- Wear clothing that allows freedom of movement.
- Avoid wearing clothes which have loose cuffs or other fastenings which

could interfere with the controls of your motorcycle.

- Wear bright, highly visible clothing.

### ***Boots***

Wear proper protective boots that fit properly and do not interfere with gear shifting or braking.

---

## **Safe Riding Techniques**

---

### ***Keep Hands on Handlebars***

When riding always keep both hands on the handlebars and both feet on the footpegs. Removing your hands from the handlebars or feet from the footpegs while riding can be hazardous. If you remove even one hand or foot, you reduce your ability to control the motorcycle.



### ***Look Over Your Shoulder***

Before changing lanes, look over your shoulder to make sure the way is clear. Do not rely solely on the rear view mirror; you may misjudge a vehicle's distance and speed, or you may not see it at all.

### ***Accelerate and Brake Smoothly***

In general your actions should be smooth as sudden acceleration, braking or turning may cause loss of control, especially when riding in wet conditions or on loose road surfaces, when the ability to maneuver will be reduced.

### ***Select Correct Gear Speeds***

When going up steep slopes, shift to a lower gear so that there is power to spare rather than overloading the engine.

### ***Use Both Front and Rear Brakes***

When applying the brakes, use both the front and rear brakes. Applying only one brake for sudden braking may cause the motorcycle to skid and lose control.

### ***Use Engine Brake***

When going down long slopes, help control vehicle speed by closing the throttle so that the engine can act as an auxiliary brake. Use the front and rear brakes for primary braking.

### ***Riding in Wet Conditions***

Rely more on the throttle to control vehicle speed and less on the front and rear brakes. The throttle should also be used judiciously to avoid skidding the rear wheel from too rapid acceleration or deceleration.

Braking performance is also reduced in wet conditions. Carefully ride at a

## 24 SAFETY INFORMATION

slow speed and apply the brakes several times to help dry and restores them to normal operating performance.

Lubricate the drive chain after wet-weather riding to prevent rust and corrosion.

### ***Ride Prudently***

Riding at the proper speed and avoiding unnecessarily fast acceleration are important not only for safety and low fuel consumption but also for long vehicle life and quieter operation.

### ***Riding on Rough Roads***

Exercise caution, slow down, and grip the fuel tank with the knees for better stability.

### ***Acceleration***

When quick acceleration is necessary to pass another vehicle, shift to a lower gear to obtain the necessary power.

### ***Downshifting***

To avoid engine damage and rear-wheel lock-up do not downshift at high rpm.

### ***Avoid Unnecessary Weaving***

Unnecessary weaving jeopardizes the safety of both the rider and other motorists.

---

## Additional Considerations for High Speed Operation

---



### **WARNING**

Handling characteristics of a motorcycle at high speeds may vary from those you are familiar with at legal highway speeds. Do not attempt high speed operation unless you have received sufficient training and have the required skills. Do not operate at high speeds on public roads.

### **Brakes**

The importance of the brakes, especially during high speed operation, cannot be overemphasized. Check to

see that they are correctly adjusted and functioning properly.

### **Steering**

Looseness in the steering can cause loss of control. Check to see that the handlebar turns freely but has no play.

### **Tires**

High speed operation is hard on tires, and good tires are crucial for safe riding. Examine their overall condition, inflate them to the proper pressure, and check the wheel balance.

### **Fuel**

Have sufficient fuel for the high fuel consumption during high speed operation.

### **Engine Oil**

To avoid engine seizure and resulting loss of control, make sure that the oil level is at the upper level line.

## 26 SAFETY INFORMATION

### ***Coolant***

To avoid overheating, check that the coolant level is at the upper level line.

### ***Electrical Equipment***

Make sure that the headlight, brake/tail light, turn signals, horn, etc., all work properly.

### ***Miscellaneous***

Make sure that all nuts and bolts are tight and that all safety related parts are in good condition.

---

# GENERAL INFORMATION

---

## Specifications

### PERFORMANCE

Minimum Turning Radius 2.6 m (8.5 ft)

### DIMENSIONS

Overall Length 1 990 mm (78.35 in.)

Overall Width 765 mm (30.12 in.)

Overall Height 1 110 mm (43.70 in.)

Wheelbase 1 380 mm (54.33 in.)

Road Clearance 135 mm (5.31 in.)

Curb Mass 188 kg (415 lb)

### ENGINE

Type DOHC, 4-cylinder, 4-stroke, liquid-cooled

Displacement 399 cm<sup>3</sup> (24.3 cu in.)

Bore × Stroke 57.0 × 39.1 mm (2.24 × 1.54 in.)

Compression Ratio 12.3:1

## 28 GENERAL INFORMATION

Starting System	Electric starter	
Cylinder Numbering Method	Left to right, 1-2-3-4	
Firing Order	1-2-4-3	
Fuel System	FI (Fuel Injection)	
Ignition System	Battery and coil (transistorized ignition)	
Ignition Timing (Electronically advanced)	10° BTDC @1 000 r/min (rpm) – 38° BTDC @6 500 r/min (rpm)	
Spark Plug:	Type	NGK LMAR9G
	Gap	0.7 – 0.8 mm (0.028 – 0.031 in.)
Lubrication System	Forced lubrication (wet sump)	
Engine Oil:	Type	API SG, SH, SJ, SL, or SM with JASO MA, MA1 or MA2
	Viscosity	SAE 10W-40
	Capacity	3.0 L (3.2 US qt)
Coolant Capacity	2.0 L (2.1 US qt)	

## TRANSMISSION

Transmission Type	6-speed, constant mesh, return shift
Clutch Type	Wet, multi disc

Driving System	Chain drive
Primary Reduction Ratio	2.029 (69/34)
Final Reduction Ratio	3.429 (48/14)
Overall Drive Ratio	7.216 (Top gear)
Gear Ratio:	
1st	2.929 (41/14)
2nd	2.056 (37/18)
3rd	1.619 (34/21)
4th	1.333 (32/24)
5th	1.154 (30/26)
6th	1.037 (28/27)

**FRAME**

Caster	23.5°
Trail	97 mm (3.8 in.)
Tire Size:	
Front	120/70ZR17 M/C (58W)
Rear	160/60ZR17 M/C (69W)
Rim Size:	
Front	17M/C × MT3.50
Rear	17M/C × MT4.50

## 30 GENERAL INFORMATION

Fuel Tank Capacity 15 L (4.0 US gal)

Brake Fluid: Front DOT4

Rear DOT4

### ELECTRICAL EQUIPMENT

Battery 12 V 8.6 Ah (10 HR)

Headlight: High Beam LED

Low Beam LED

City Light LED

Brake/Tail Light LED

Turn Signal Light: Front LED

Rear LED

License Plate Light LED

Even if any one element of LED (Light Emitting Diode) light does not go on, consult with an authorized Kawasaki dealer.

Specifications are subject to change without notice.



## Serial Number Locations

The engine and frame serial numbers are used to register the motorcycle. They are the only means of identifying your particular machine from others of the same model type. These serial numbers may be needed by your dealer when ordering parts. In the event of theft, the investigating authorities will require both numbers as well as the model type and any peculiar features of your machine that can help them identify it.

### Engine No.

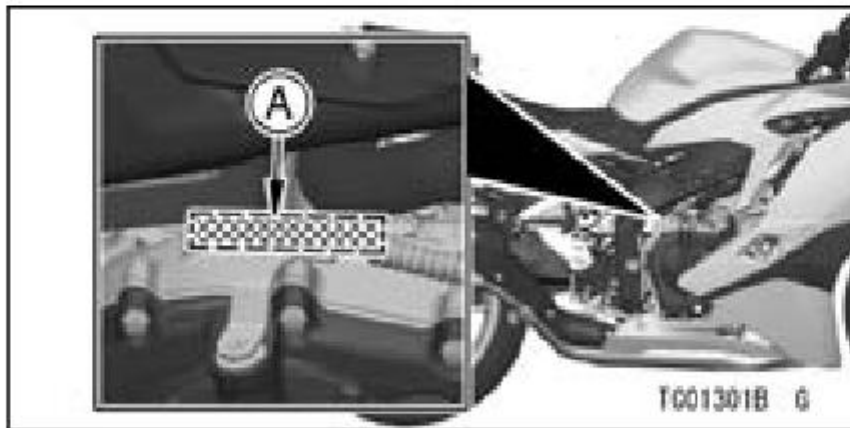

A. Engine Number

### Frame No.

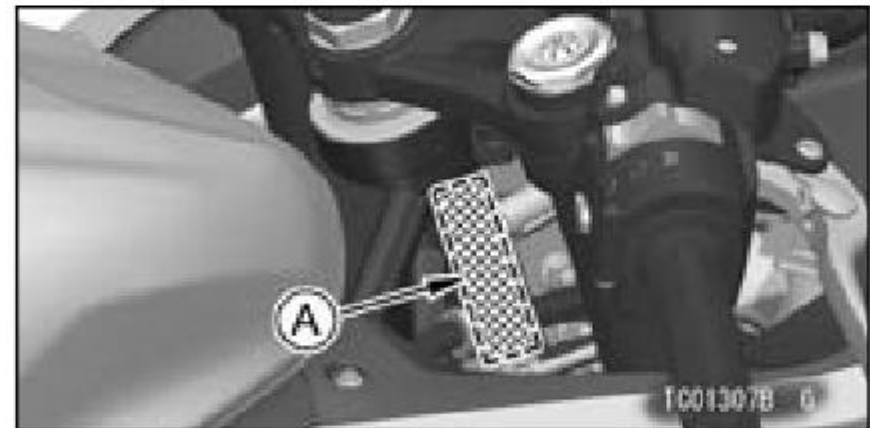

A. Frame Number

### Location of Labels

All warning labels which are on your vehicle are repeated here. Read labels on your vehicle and understand them thoroughly. They contain information which is important for your safety and the safety of anyone else who may operate your vehicle. Therefore, it is very important that all warning labels be on your vehicle in the locations shown. If any label is missing, damaged, or worn, get a replacement from your Kawasaki dealer and install it in the correct position.

#### NOTE

- *Refer to the actual vehicle label for model specific data grayed out in the illustration.*



**1. Brake Fluid (Front)**

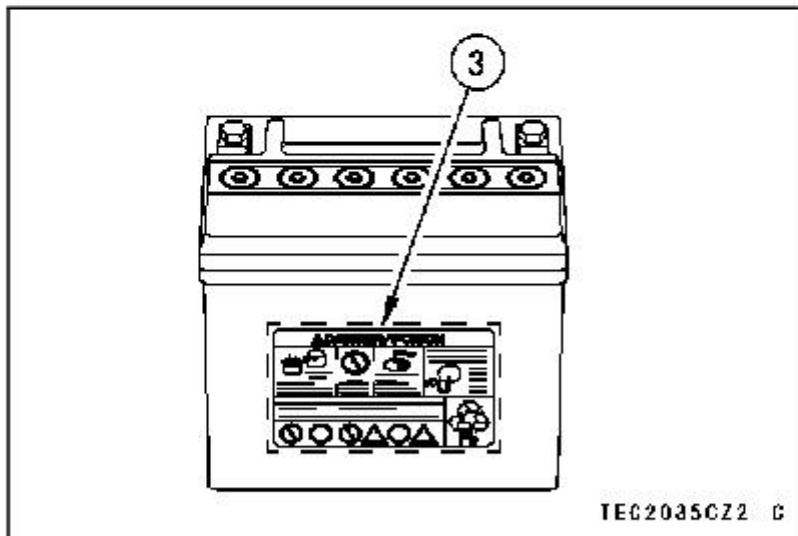

- 2. Brake Fluid (Rear)
- 3. Battery Poison/Danger
- 4. Rear Shock Absorber Warning

## 34 GENERAL INFORMATION

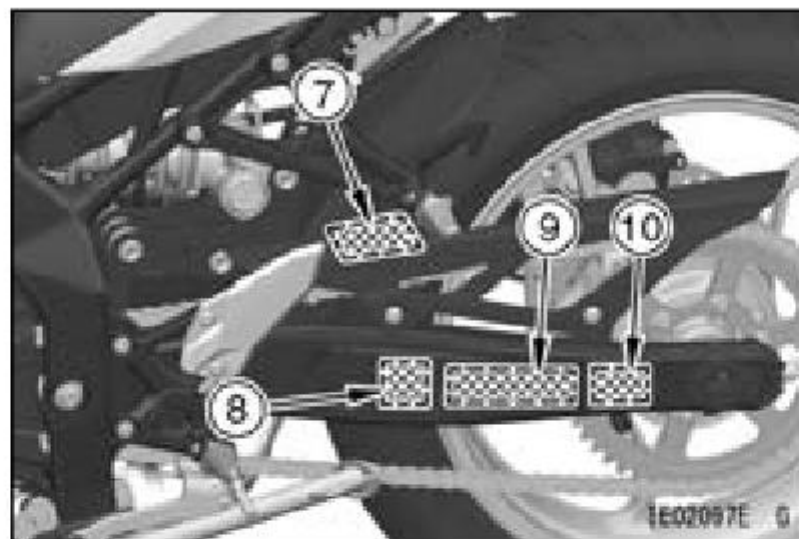

- 5. Radiator Cap Danger
- 6. Fuel Level
- 7. Tire and Load Data
- 8. Vacuum Hose Routing Diagram
- 9. Important Drive Chain Information
- 10. Noise Emission Control Information

- 11. Vehicle Emission Control Information
- 12. Weight and Manufacture



## 36 GENERAL INFORMATION

1)

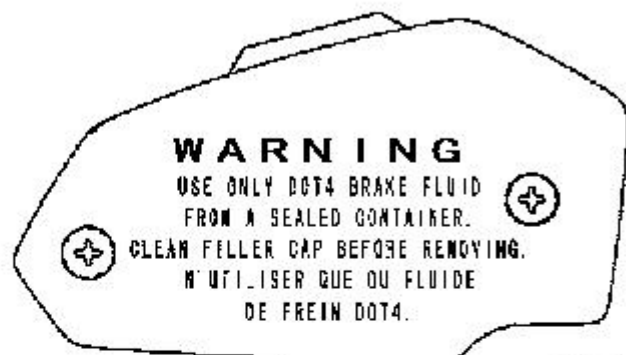

TE038418N9 C

3)



TE03189E S

2)



TE03879DN9 C

4)

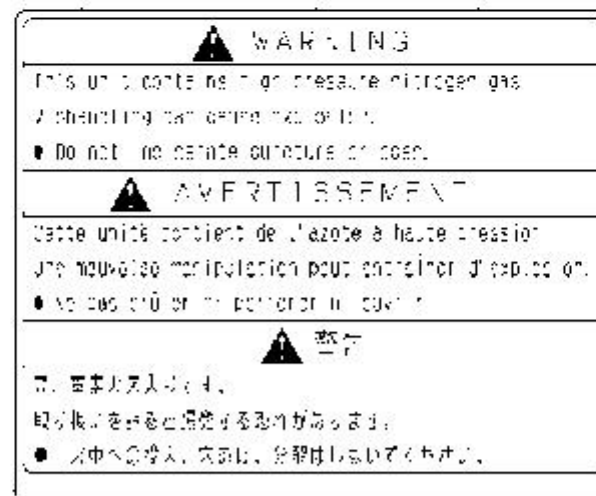

TE03198F S

5)



TE03079E S

7)

⚠ WARNING			
Use of tires with improper inflation or excessive wear, unsuitable replacement tires or overloading can result in a loss of control causing serious bodily injury. See Owner's Manual for additional information.			
TIRE AND LOAD DATA			
	Air Pressure (Cold)	Size & Make Type	Minimum tread depth
Front	35 psi 2.3 bar (3.0 kg/cm <sup>2</sup> )	P181 7P (20/190Z17 M/C 65W) SPORTMAX GT2-300F W	1 mm (0.04 in)
Up to 180 kg load (397 lbs)			
Rear	250 psi 17.2 bar (22.4 kg/cm <sup>2</sup> )	DUNLOP 200/180ZR17 M/C 65W SPORTMAX GT2-300 W	Up to 100 km/h (62 MPH) a min 0.32 in Over 100 km/h (62 MPH) a min 0.75 in

TE03539FZ2 S

## Location of Parts

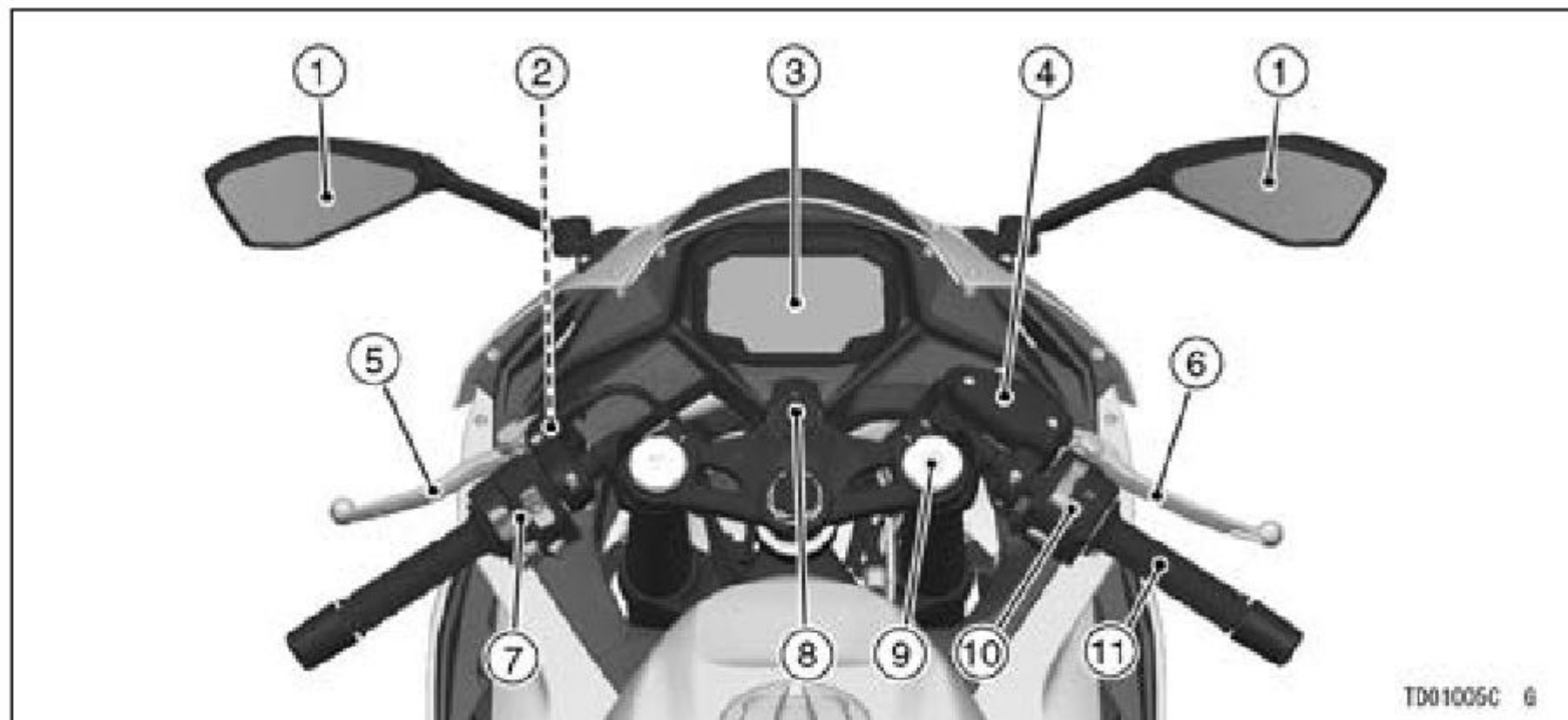

- 1. Rear View Mirrors
- 2. Starter Lockout Switch
- 3. Meter Instrument
- 4. Brake Fluid Reservoir (Front)
- 5. Clutch Lever
- 6. Front Brake Lever

- 7. Left Handlebar Switches
- 8. Ignition Switch/Steering Lock
- 9. Spring Preload Adjuster
- 10. Right Handlebar Switches
- 11. Throttle Grip



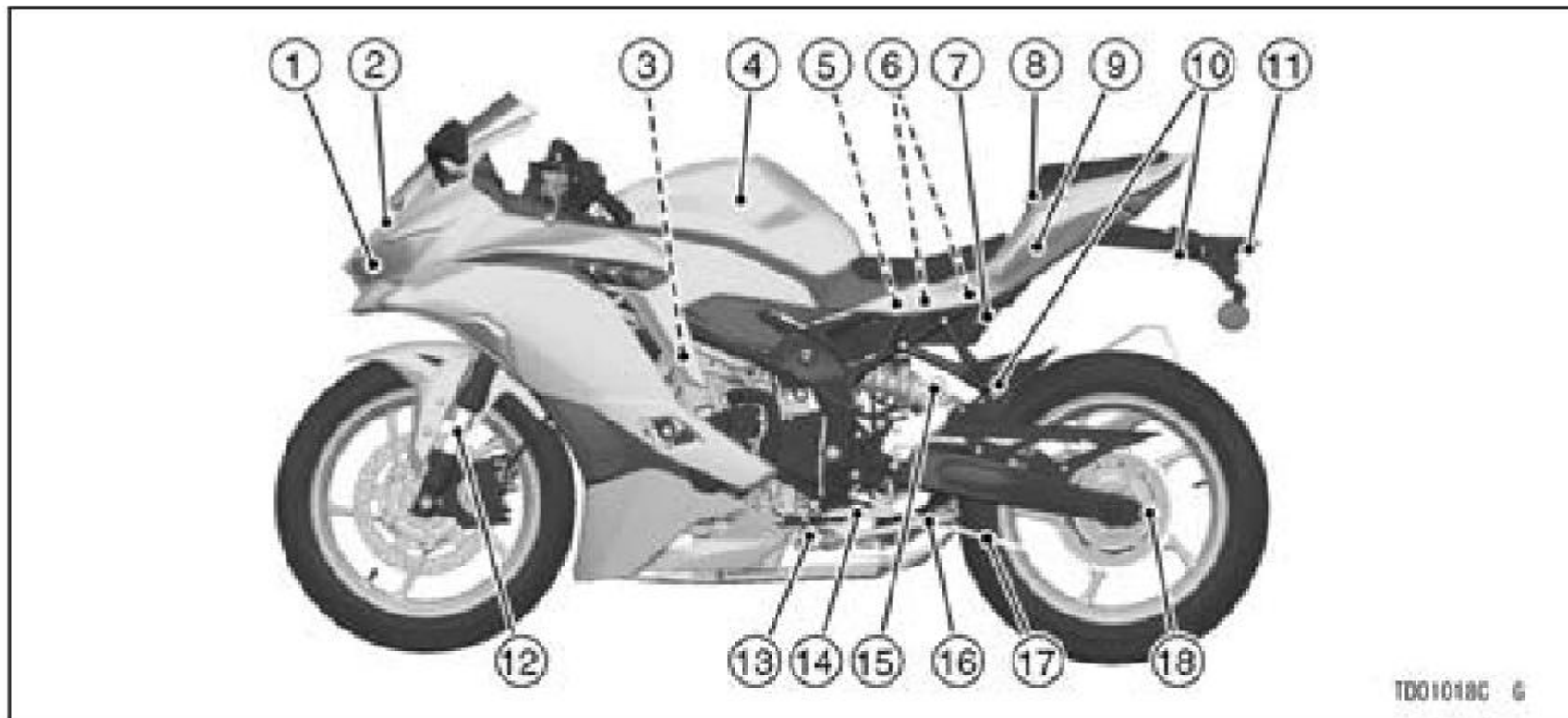

- 1. Headlight
- 2. Air Cleaner Intake
- 3. Spark Plugs
- 4. Fuel Tank
- 5. Battery
- 6. Fuse Boxes
- 7. Helmet Lock
- 8. Seat Strap
- 9. Seat Lock

- 10. Tie Hooks
- 11. License Plate Light
- 12. Front Fork
- 13. Side Stand Switch
- 14. Shift Pedal
- 15. Damping Force Adjusters
- 16. Side Stand
- 17. Drive Chain
- 18. Chain Adjuster

## 40 GENERAL INFORMATION

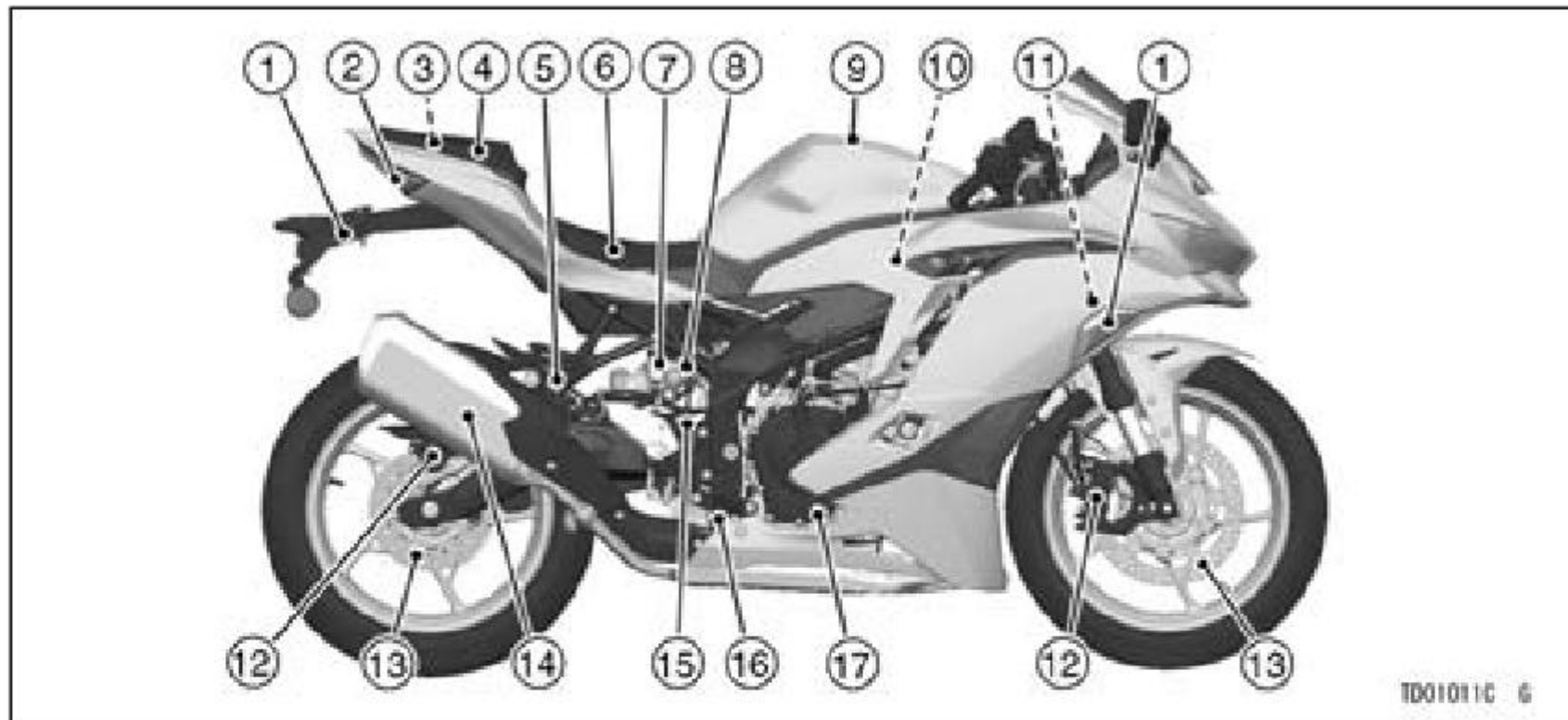

1. Turn Signal Lights
2. Brake/Tail Light
3. Tool Kit
4. Passenger's Seat
5. Rear Footpeg
6. Rider's Seat
7. Brake Fluid Reservoir (Rear)
8. Rear Shock Absorber
9. Fuel Tank Cap

10. Air Cleaner
11. Coolant Reserve Tank
12. Brake Calipers
13. Brake Discs
14. Muffler
15. Rear Brake Light Switch
16. Brake Pedal
17. Oil Level Inspection Window

## Meter Instruments

The display layout can be switched from two different types. Refer to the Menu Mode section.



- 1. Display Screen
- 2. Right Meter Button

- 3. Ambient Brightness Sensor
- 4. Left Meter Button

## 42 GENERAL INFORMATION

### Display Layout (Type 1)

1. Gear Position Indicator
2. Integrated Riding Mode Indicator
3. KQS Mode Indicator
4. Tachometer
5. Speedometer
6. Clock
7. Coolant Temperature Meter
8. Multifunction Display
  - Odometer
  - Trip Meter A/B
  - Current Mileage
  - Average Mileage
  - Cruising Range
  - Average Speed
  - Total Time
  - Battery Voltage
9. Service Indicator
10. Bluetooth® Connection Indicator
11. Fuel Gauge
12. Economical Riding Indicator

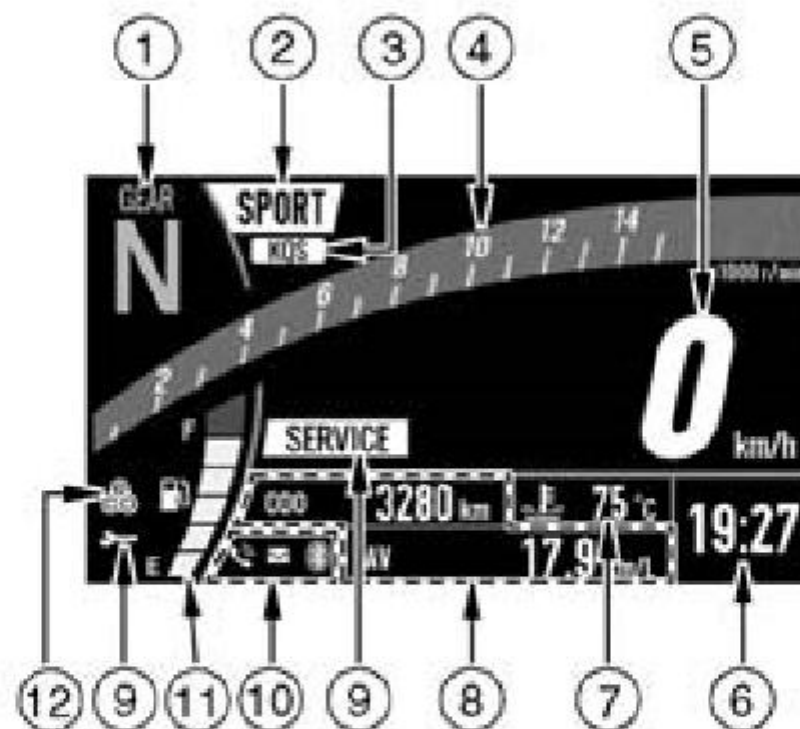

TG02630E G

**Display Layout (Type 2)**

1. Clock
2. Tachometer
3. Gear Position Indicator
4. Stopwatch (Measurement Display)
5. Service Indicator
6. Integrated Riding Mode Indicator
7. Stopwatch (Information Display)
8. Speedometer
9. Coolant Temperature Meter
10. Multifunction Display
  - Odometer
  - Trip Meter A/B
11. KQS Mode Indicator
12. Bluetooth® Connection Indicator

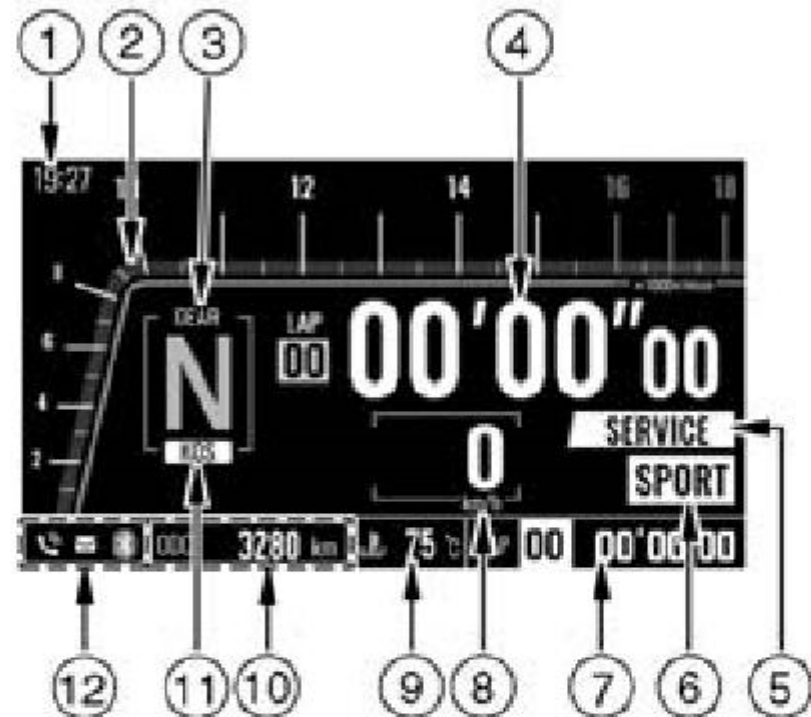

## 44 GENERAL INFORMATION

### **Background Color Change**

- When the current mileage, cruising range, battery voltage or stopwatch is displayed on multifunction display, pushing and holding the right meter button to invert the background color of the display screen.

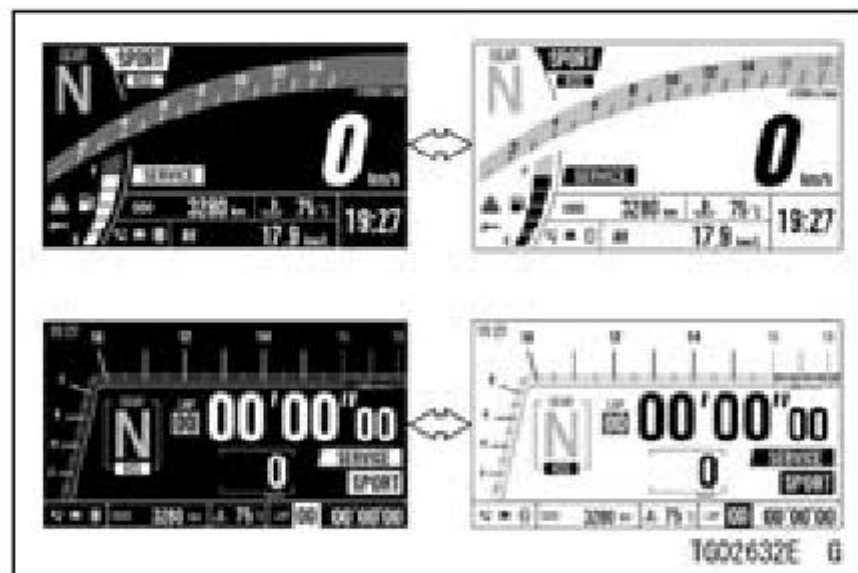

↔ : Flow when pushing and holding the right meter button

### **NOTE**

- When the average mileage, average speed or total time is displayed on multifunction display, pushing and holding right meter button resets item and the background color of the display screen does not invert.

### **Ambient Brightness Sensor**

The brightness of the meter instrument is controlled automatically depending on the ambient brightness.

### **NOTE**

- Be careful not to cover the ambient brightness sensor on the meter instrument while riding the motorcycle.

### **Meter Instrument Brightness Setting**

- The brightness of the meter instrument can be adjusted manually in two levels. Refer to Brightness in the Menu Mode section.

## Indicators

- |     |   |   |
|-----|---|---|
| 1.  |  | Right Turn Signal Indicator (Green)         |
| 2.  |  | Neutral Indicator (Green)                   |
| 3.  |  | KTRC Indicator (Yellow)                     |
| 4.  |  | ABS Indicator (Yellow)                      |
| 5.  |  | Fuel Level Warning Indicator (Yellow)       |
| 6.  |  | Oil Pressure Warning Indicator (Red)        |
| 7.  |  | Coolant Temperature Warning Indicator (Red) |
| 8.  |  | Battery Warning Indicator (Red)             |
| 9.  |  | Engine Warning Indicator (Yellow)           |
| 10. |  | High Beam Indicator (Blue)                  |
| 11. |  | Left Turn Signal Indicator (Green)          |

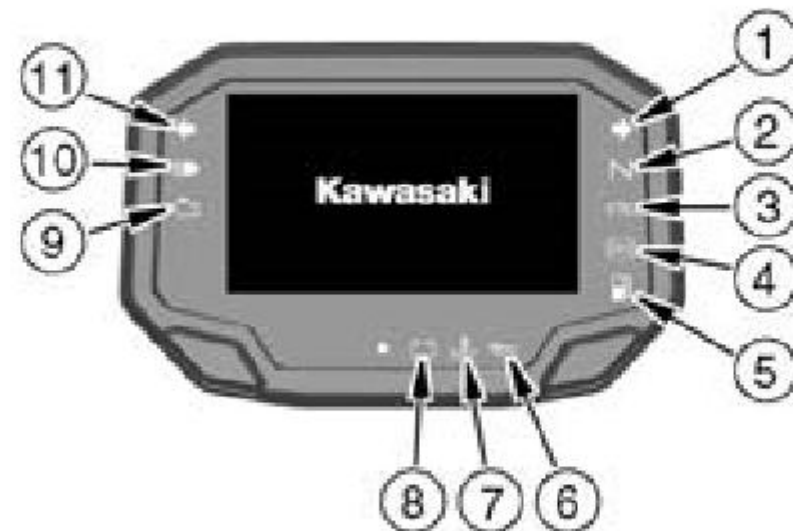







## 46 GENERAL INFORMATION

### *Indicator Initial Operation*





TG02667E G

When the ignition switch is turned on, all indicators go on/off as shown in the table. If any indicator does not operate as shown, have it checked by an authorized Kawasaki dealer.

ON			Indicators	
<input type="checkbox"/>	<input type="checkbox"/>	<input type="checkbox"/>	   <u>N</u>	
<input type="checkbox"/>	<input type="checkbox"/>	<input checked="" type="checkbox"/>	   	
<input type="checkbox"/>	<input checked="" type="checkbox"/>	<input checked="" type="checkbox"/>	      KTRC	

ON: When ignition switch is turned on.

: After a few seconds

: When engine starts.

: Goes on.



: Goes off.

\*:  | goes off shortly after the motorcycle starts moving.





### ***When Warning Indicators Go On or Blink***

When warning indicators appear, there could be a problem with vehicle function. Follow actions in the table after stopping the vehicle in a safe place.

Indicators	Status	Actions
	ON	This indicator goes on if the battery voltage is less than 11.0 V or more than 16.0 V. If the voltage is less than 11.0 V, charge the battery. If it does not solve the problem, contact an authorized Kawasaki dealer.
	ON	This indicator goes on whenever the coolant temperature rises too high when the motorcycle is in operation. Stop the engine and check the coolant level in the reserve tank after the engine cools down. If the amount of coolant is insufficient, add coolant to the reserve tank. Contact an authorized Kawasaki dealer.
	ON	This indicator goes on whenever the oil pressure is dangerously low or the ignition switch is turned on with the engine not running. If this indicator goes on when the engine speed is above idle, stop the engine immediately and check the engine oil level. If the amount of engine oil is insufficient, add engine oil. If the oil level is good, contact an authorized Kawasaki dealer.

## 48 GENERAL INFORMATION

Indicators	Status	Actions
	ON	Usable Fuel Remains: Approximately 4.2 L (1.1 US gal)
		Refuel at the earliest opportunity. If the vehicle is on the side stand, the warning indicator cannot estimate the amount of fuel in the tank. Stand the vehicle upright to check the fuel level.
	Blink	The fuel level warning system has malfunctioned. Contact an authorized Kawasaki dealer.

Indicators	Status	Actions
	ON	The DFI system has malfunctioned. Contact an authorized Kawasaki dealer.
	Blink	
	ON	ABS indicator may go on under following specific condition* <sup>1</sup> . If this indicator appears, first turn the ignition switch off, and then back on, and ride the motorcycle. The ABS indicator should then go off. If it does not, the ABS may have malfunctioned. ABS will not work but conventional brakes function. Contact an authorized Kawasaki dealer.

- \*1:
- After continuous riding on a rough road.
  - When the engine is started with the stand raised and the transmission engaged, and the rear wheel turns.
  - When accelerating so abruptly that the front wheel leaves the ground.
  - When the ABS has been subjected to strong electrical interference.
  - When tire pressure is abnormal. Adjust tire pressure.
  - When a tire different in size from the standard size is being used. Replace with standard size.
  - When the wheel is deformed. Replace the wheel.

## 50 GENERAL INFORMATION

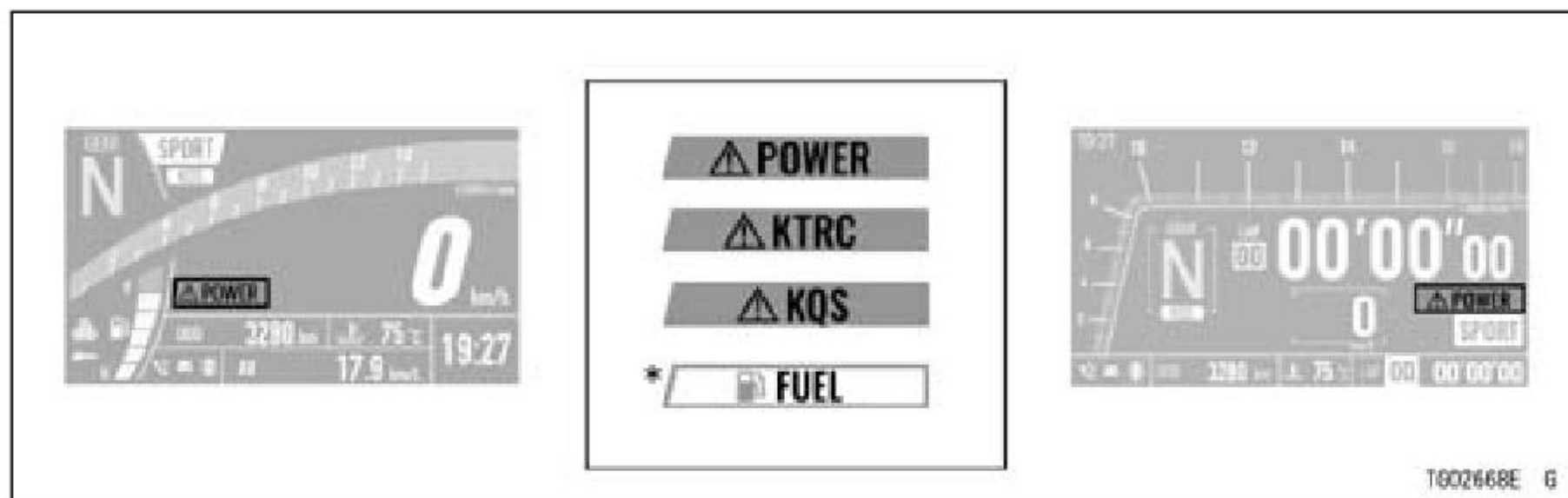

### When Warning Messages Display

When warning messages appear, there could be a problem with vehicle function. Have them checked by an authorized Kawasaki dealer.



\*: Only on display layout Type 2

## Other Indicators

Indicators	Status
	When the turn signal switch is pushed to the left, this indicator blinks.
	When the turn signal switch is pushed to the right, this indicator blinks.
	When the headlight is on high beam, this indicator goes on.
N	When the transmission is in neutral, this indicator goes on.
KTRC	When the KTRC functions, this indicator blinks.

## Speedometer/Tachometer

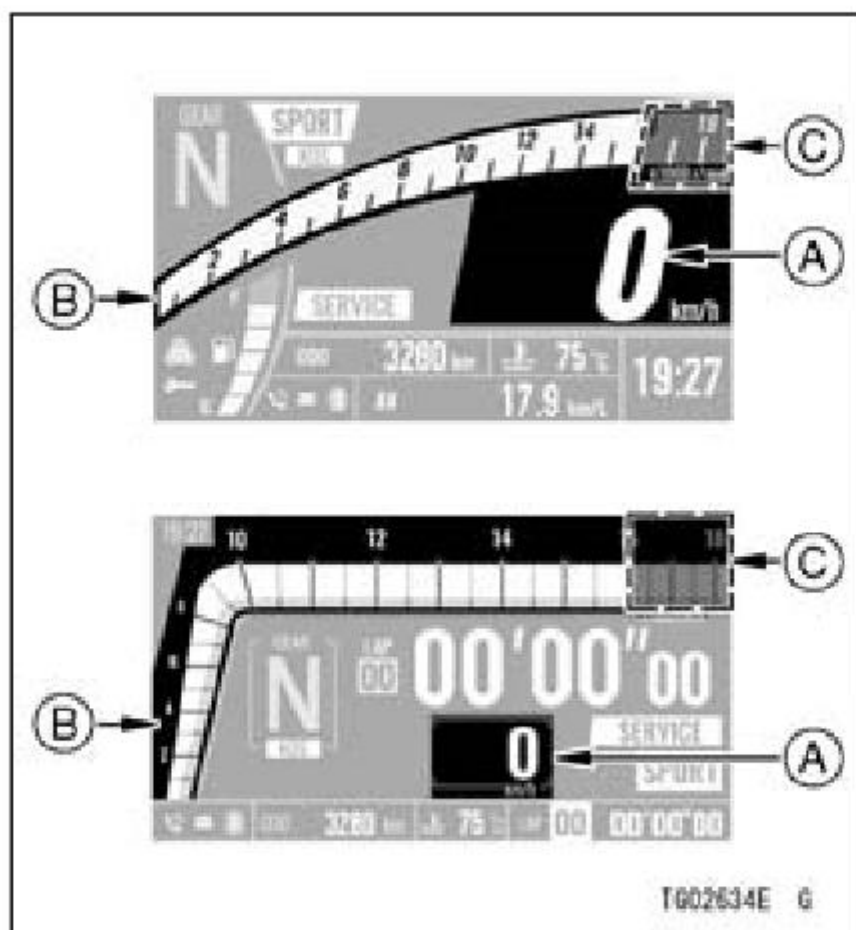

- A. Speedometer
- B. Tachometer
- C. Red Zone

### **Speedometer**

The speedometer is digital and can be set for km/h or mph.

The unit setting can be changed according to local regulations. Make sure the unit setting (km/h or mph) is correctly displayed before riding. Refer to the Menu Mode section.

### **Tachometer**

The tachometer shows the engine speed in revolutions per minute (r/min, rpm).

### **NOTICE**

**Engine speed should not be allowed to enter the red zone; operation in the red zone will overstress the engine and may cause serious engine damage.**

The tachometer also serves as the shift-up indicator.

## Features

### Coolant Temperature Meter

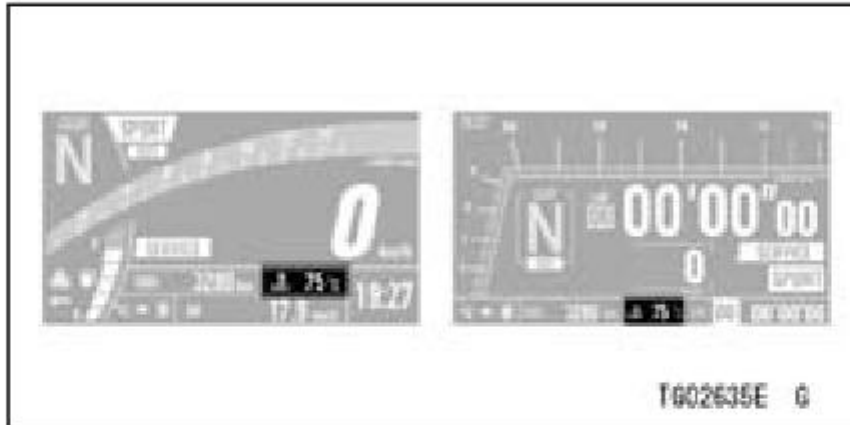

This meter shows the coolant temperature. The meter display is as shown below.

Coolant Temperature	Meter
Below 40°C (104°F)	"- - -" is displayed
Above 115°C (239°F)	Starts blinking
Above 120°C (248°F)	"Hi" appears and starts blinking



**A. Coolant Temperature Warning Indicator**

## NOTICE

Stop the engine if the coolant temperature shows “Hi.” Prolonged engine operation will result in severe engine damage from overheating.

### *Gear Position Indicator*

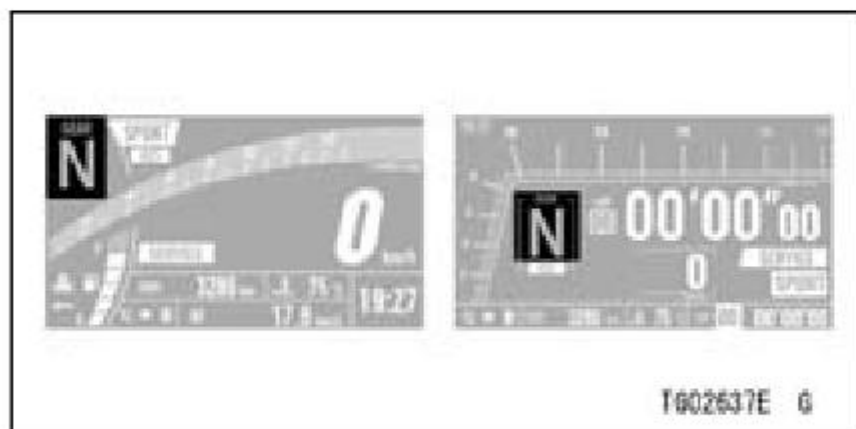

The current gear position is shown. When the transmission is in neutral, “N” appears.

## NOTE

○ *If the transmission gears are not engaged properly, the gear position indicator disappears.*

The gear position indicator also serves as the shift-up indicator function.

### ***Shift-up Indicator Function***

The shift-up indicator function indicates the timing for the next up shift. From 500 r/min (rpm) before reaching the set engine speed, the gear position indicator changes color to orange, the tachometer and the gear position indicator starts blinking slowly. When the engine speed reaches the set value, the tachometer also changes color to orange, and the gear position indicator and the tachometer blinks rapidly.



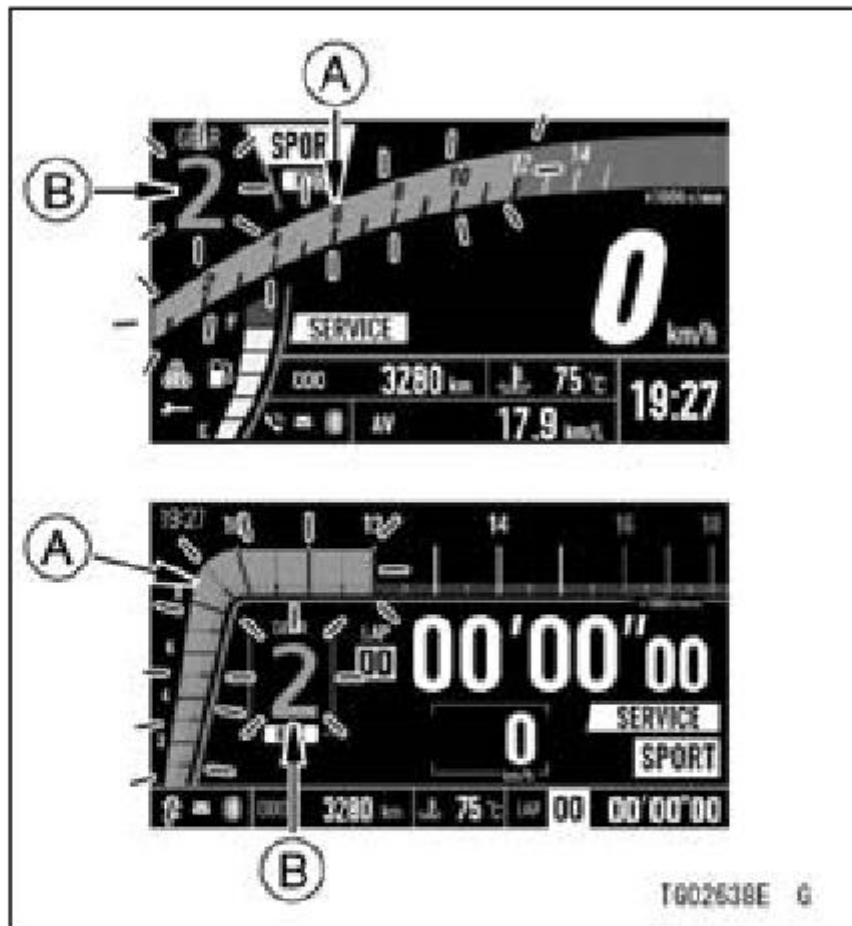

- A. Tachometer (Change color to orange and blink)
- B. Gear Position Indicator (Change color to orange and blink)

The shift-up indicator function can be selected on or off, and the set value can be adjusted.

### ***Shift-up Indicator Function Setting***

- Refer to Vehicle Settings in the Menu Mode section.

### ***Fuel Gauge***

(Only on display layout Type 1)

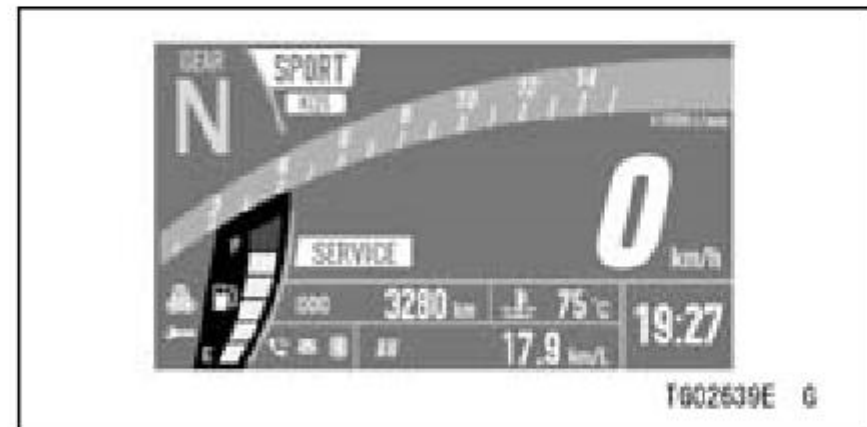

The fuel level in the fuel tank is shown by the number of segments displayed between E (empty) and F (full).

## NOTE

- When the fuel level warning indicator goes on or blinks, refer to *When Warning Indicators Go On or Blink in the Indicators section.*

### ***Integrated Riding Mode Indicator***



The current setting of the integrated riding mode is shown. Refer to the Integrated Riding Modes section in the HOW TO RIDE THE MOTORCYCLE chapter.

### ***KQS Mode Indicator***



The current setting of the KQS is shown. Refer to the KQS section in the HOW TO RIDE THE MOTORCYCLE chapter.

### ***Bluetooth® Connection Indicator***



The bluetooth icon appears when your smart device is connected to the vehicle. The telephone icon appears when a phone call is received by your smart device. The mail icon appears when a email or text message is received.



- A. Telephone Icon
- B. Mail Icon

### ***How to Setup Bluetooth Connection***

- Refer to Bluetooth in the Menu Mode section.

### **Bluetooth® Connectivity**

This motorcycle can connect to the smart device via built-in Bluetooth wireless technology.

Using the application “RIDEOLOGY THE APP,” several data of your vehicle can be accessed, and several setting items can be adjusted. Refer to the application for details.



## **WARNING**

**For safety, do not use a smart device while riding the motorcycle.**

## **NOTE**

- *Some smart devices may not be compatible even if Bluetooth technology is available.*
- *The Bluetooth® word mark and logos are registered trademarks owned by Bluetooth SIG, Inc.*



### ***Economical Riding Indicator (Only on display layout Type 1)***

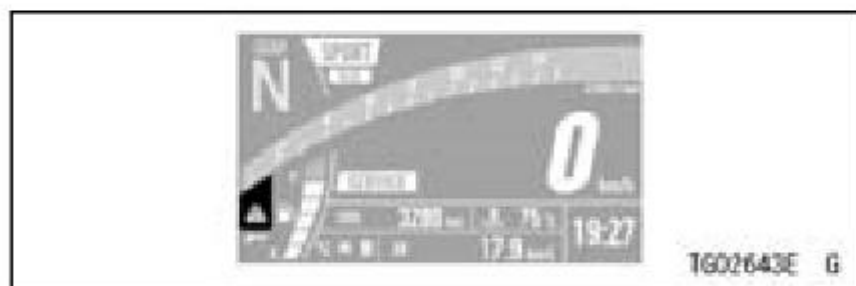

When riding the motorcycle efficiently, the economical riding indicator appears on the LCD to indicate favorable fuel consumption. Monitoring the economical riding indicator can help the rider maximize fuel efficiency.

**⚠ WARNING**

Failure to observe the road ahead increases the chance of an accident resulting in severe injury or death. Do not continually focus your vision on the economical riding indicator.

### ***Service Indicator***

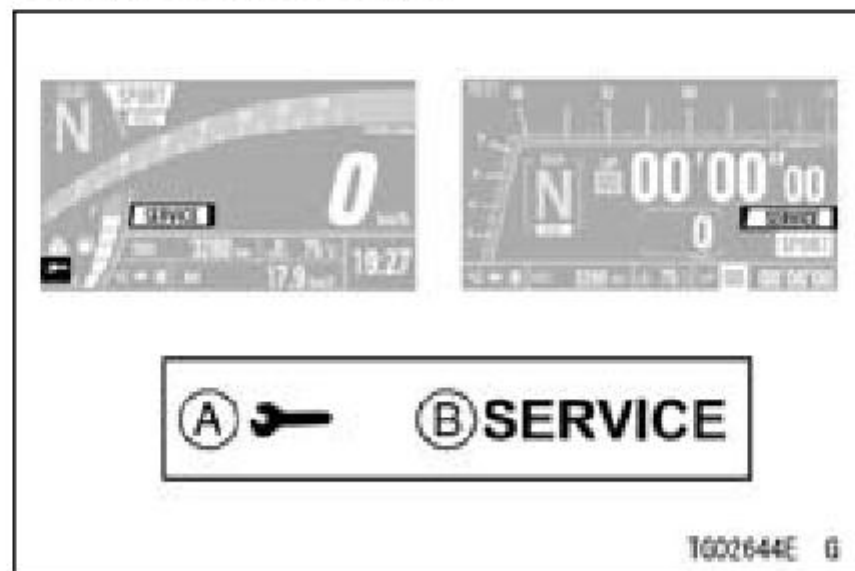

- A. Service Indicator
- B. "SERVICE" Message

This motorcycle has three types of maintenance reminders; the standard Kawasaki maintenance schedule, user defined interval for oil, and user defined interval for regular maintenance to assist you with maintenance on your Kawasaki.

When the date or distance reaches to the set value, the service indicator and message appear on the display screen every time the ignition switch is turned on.

Only “SERVICE” message disappears after 30 seconds.

#### ***Maintenance Reminder Setting***

- Refer to Service in the Menu Mode section.

## **Control Buttons**

The upper and lower buttons on the left handlebar and left and right buttons on the meter are used to operate the various functions of the display screen.

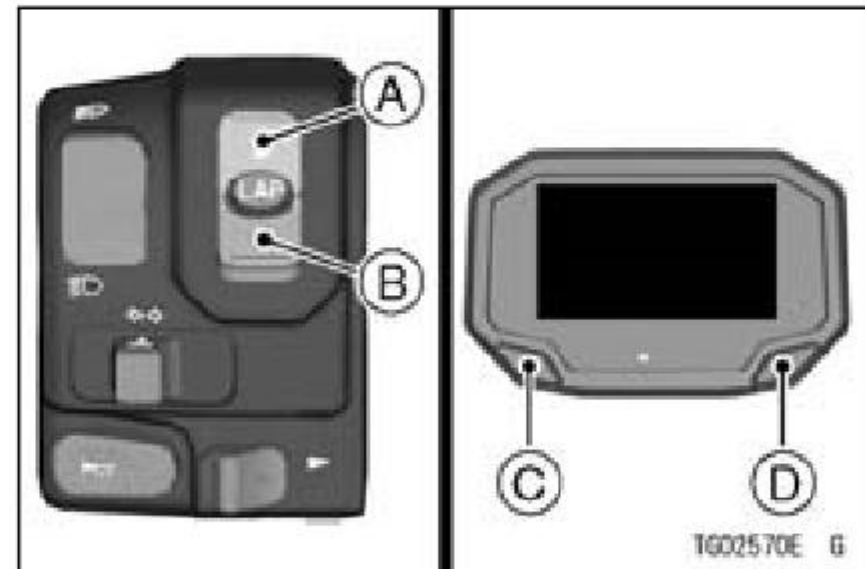

- A. Upper Button
- B. Lower Button
- C. Left Meter Button
- D. Right Meter Button

## Multifunction Display

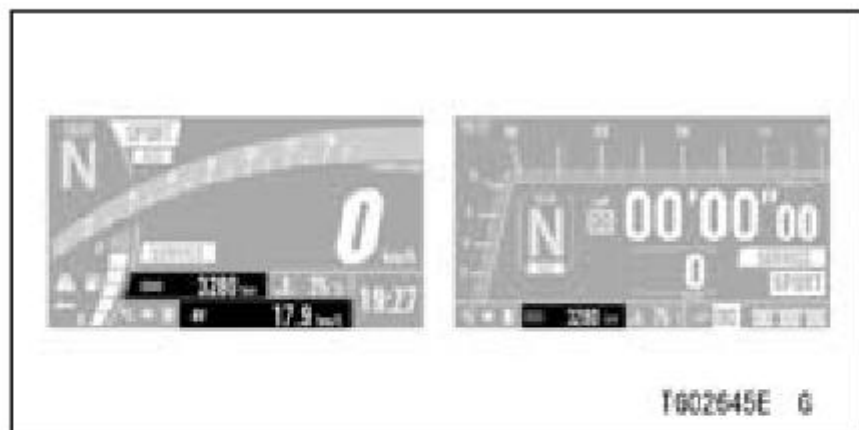

- Push the upper or left meter button to select the items shown below. The display items are switched in the following order.

### NOTE

- *For the display layout type 2, the display items are not switched in the following order when push the upper button.*

Odometer
Trip Meter A
Trip Meter B

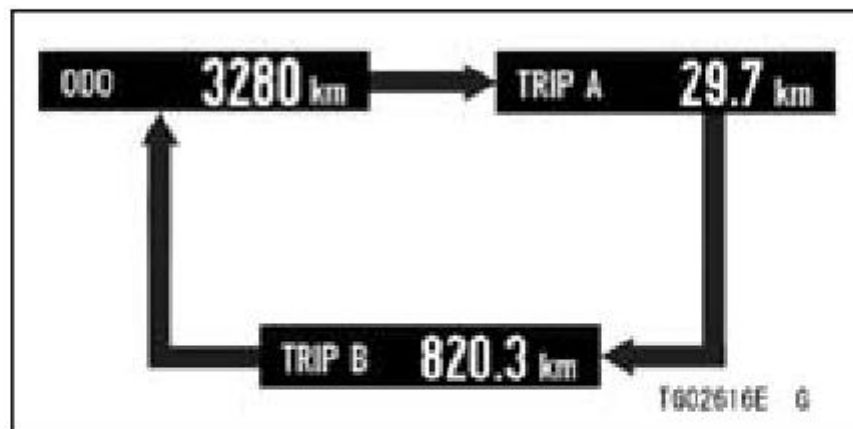

➔ : Flow when pushing upper or left meter button

- For the display layout type 1, push the lower or right meter button to select the items shown below. The display items are switched in the following order.

Current Mileage
Average Mileage
Cruising Range
Average Speed
Total Time
Battery Voltage

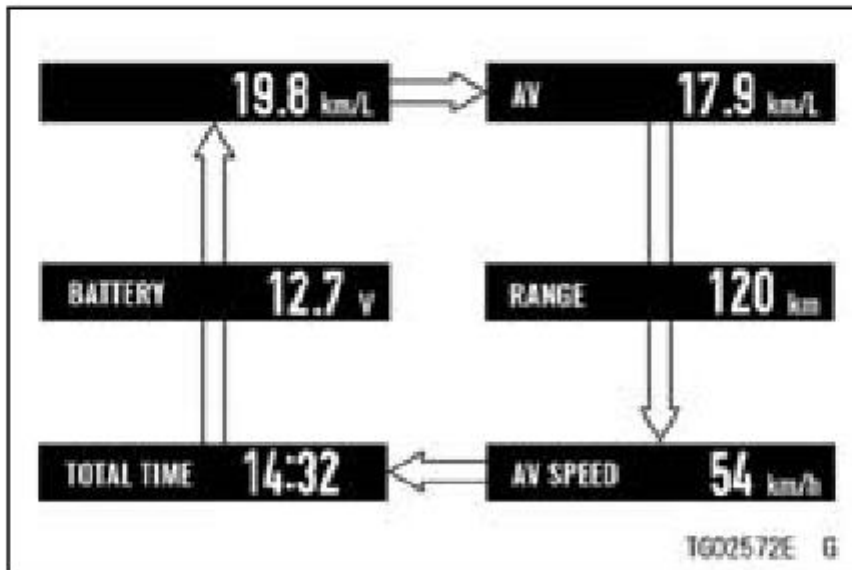

⇒ : Flow when pushing lower or right meter button

## Odometer



The odometer shows the total distance. This meter cannot be reset.

### NOTE

○ When the figures come to 999999, the display is stopped and locked.

## Trip Meter

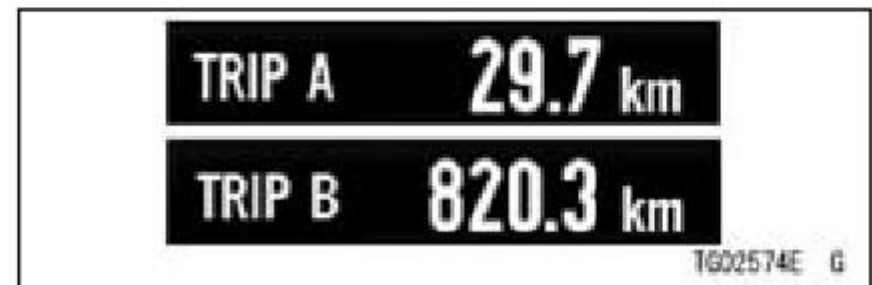

The trip meter shows the distance traveled since it was reset.

## 62 GENERAL INFORMATION

### NOTE

- When the trip meter reaches 9999.9 while riding, the meter resets to 0.0 and continues counting.

#### **How to Reset**

Refer to the Multifunction Display Re-setting section.

#### **Current Mileage**



This shows the instantaneous rate of fuel consumption.

### NOTE

- When the ignition switch is turned on, the numerical value shows “-.-.”

*After a few seconds of riding the numerical value is displayed.*

#### **Average Mileage**



This shows the average rate of fuel consumption since it was reset.

#### **How to Reset**

Refer to the Multifunction Display Re-setting section.

#### **Cruising Range**





This indicates the cruising range from the remaining fuel in the fuel tank.

### NOTE

- *When there is sufficient fuel, “(+)” appears next to the cruising range value.*
- *The cruising range value is no longer shown if the fuel level gets too low after the fuel level warning indicator goes on.*
- *To recover the cruising range display, add fuel to at least the level needed for the fuel level warning indicator goes off. The cruising range value may still be displayed with a low fuel level, but it will not be accurate until enough fuel is added to stop the fuel level warning indicator goes on.*

### Average Speed



This shows the average vehicle speed since it was reset.

#### **How to Reset**

Refer to the Multifunction Display Re-setting section.

### Total Time



This shows the amount of time that has elapsed while the ignition switch is turned on.

## 64 GENERAL INFORMATION

### NOTE

- *When the figures come to 99:59, the display is stopped and locked.*

### How to Reset

Refer to the Multifunction Display Resetting section.

### Battery Voltage



This shows the current battery voltage.

### NOTE

- *The battery voltage is displayed in the 9.0 – 16.0 V range. If the display range is exceeded, the indication is*

*fixed at the maximum or minimum value.*

- *The battery voltage shown in this display may differ from the numerical value measured by a volt meter.*

---

## Multifunction Display Resetting

---

For the display layout type 1, the following multifunction display items can be reset.

Trip Meter A/B
Average Mileage
Average Speed
Total Time

- Push the left or right meter button to display the items can be reset.
- Push the left or right meter button and hold it until resetting is done.

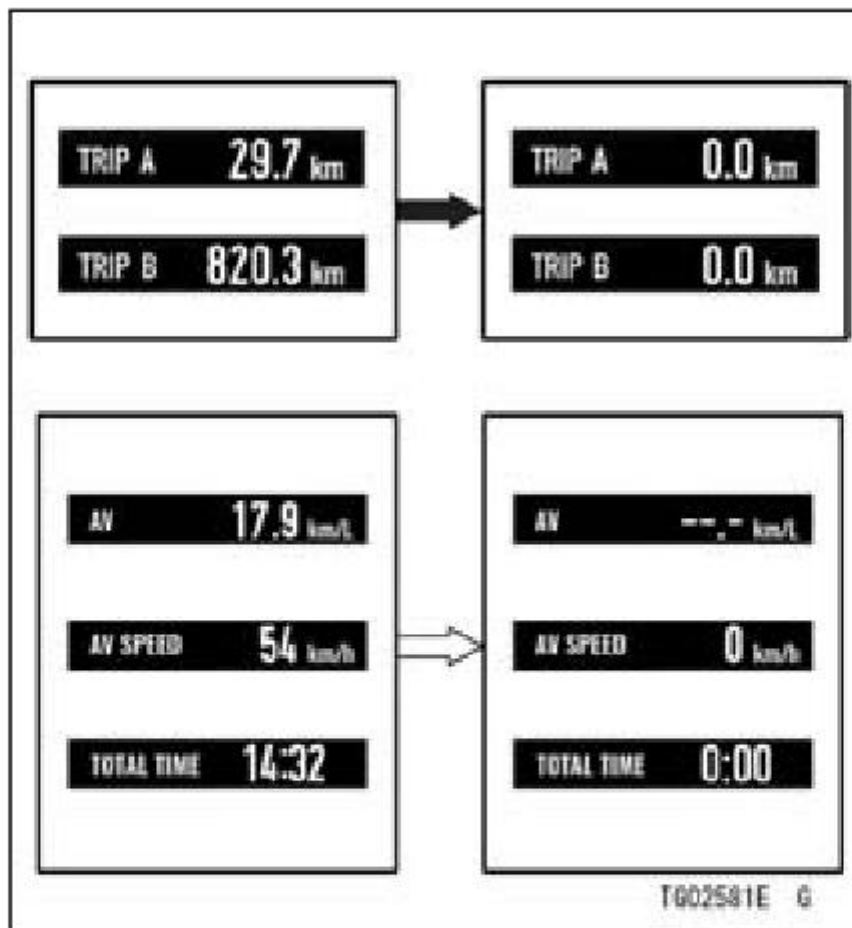

## Menu Mode

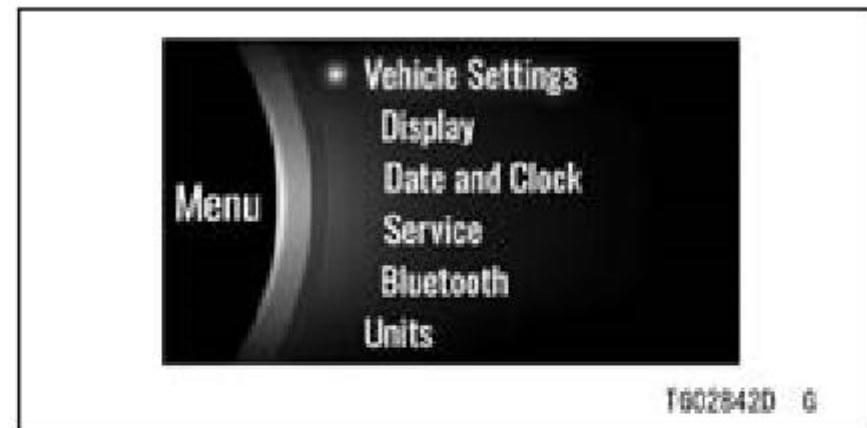

The menu mode can set various functions of the vehicle.

### NOTE

- When the vehicle speed exceeds 5 km/h (3 mph), the menu mode cannot be displayed.

### How to Enter/Exit Menu Mode

- Push and hold the left and right meter button to enter or exit.

## 66 GENERAL INFORMATION

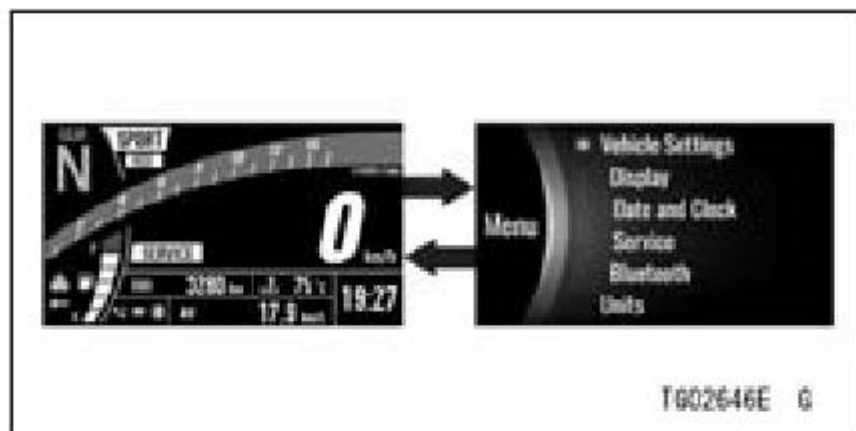

➔ : Flow when pushing and holding left and right meter button

### *Basic Operations in Menu Mode*

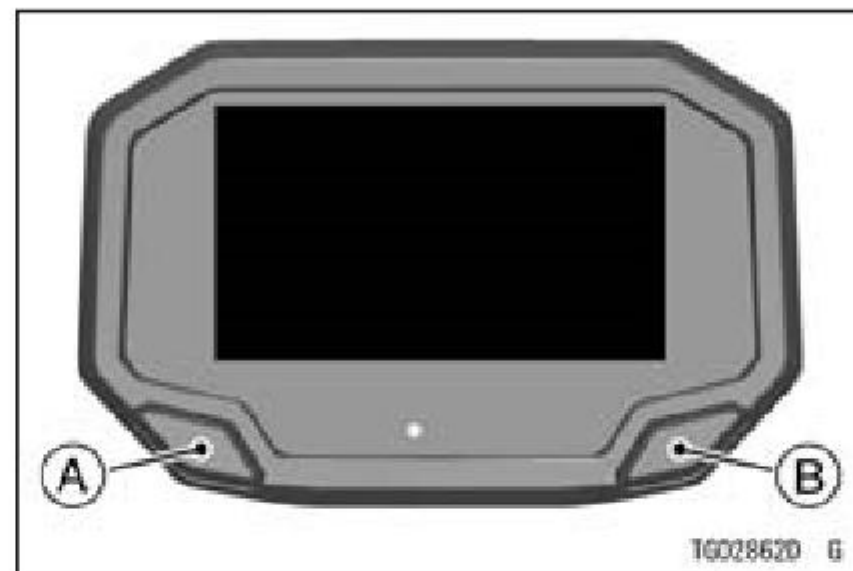

- A. Move highlighted item or choose item
- B. Shift to next screen (set) or go back to previous screen (cancel)

## Vehicle Settings



**Shift Lamp:** Turn shift-up indicator system on or off

**Engine Speed:** Adjust engine speed of shift-up indicator

**Immobilizer Lamp:** Turn immobilizer warning indicator blinking mode on or off

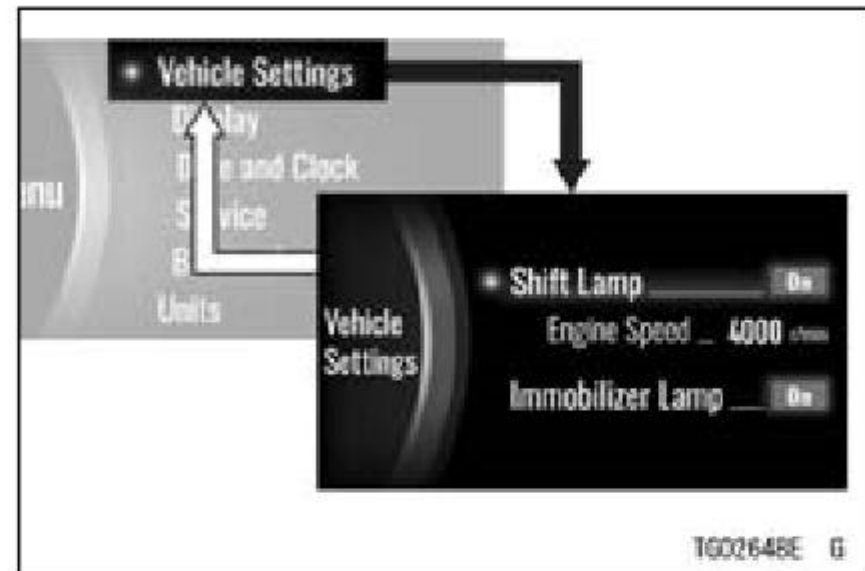

➔ : Flow when pushing the right meter button

➞ : Flow when pushing and holding the right meter button

### Shift Lamp

This switches the shift-up indicator function on or off.

- Highlight "Shift Lamp" using the left meter button.
- Push the right meter button to shift to the next screen.

## 68 GENERAL INFORMATION

- Choose on or off using the left meter button.
- Push the right meter button.

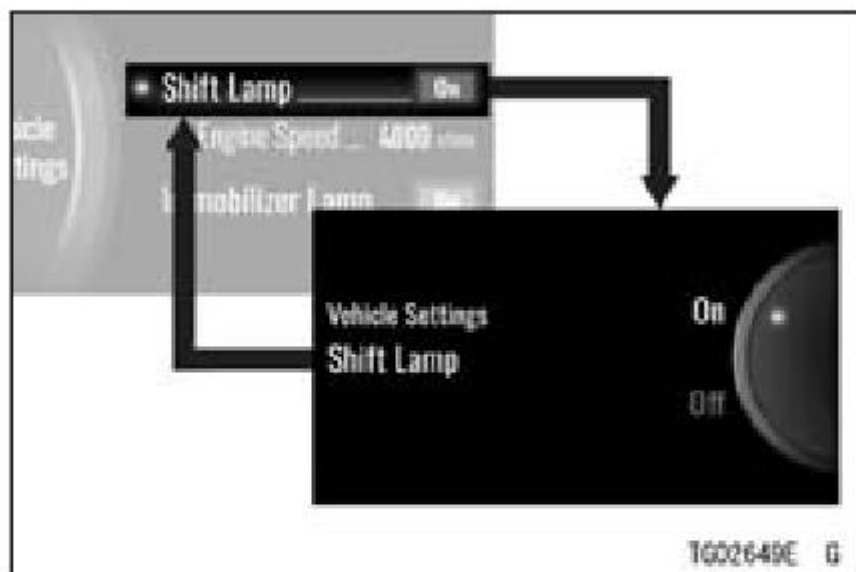

➔ : Flow when pushing the right meter button

### NOTE

- Refer to the Features section for details of the shift-up indicator function.

### Engine Speed

This adjusts the timing at which the shift-up indicator works.

### NOTE

- When “Shift Lamp” setting is off, this item is grayed out.
- Highlight “Engine Speed” using the left meter button.
- Push the right meter button to shift to the next screen.
- Set the desired engine speed using the left meter button.
- Push the right meter button.

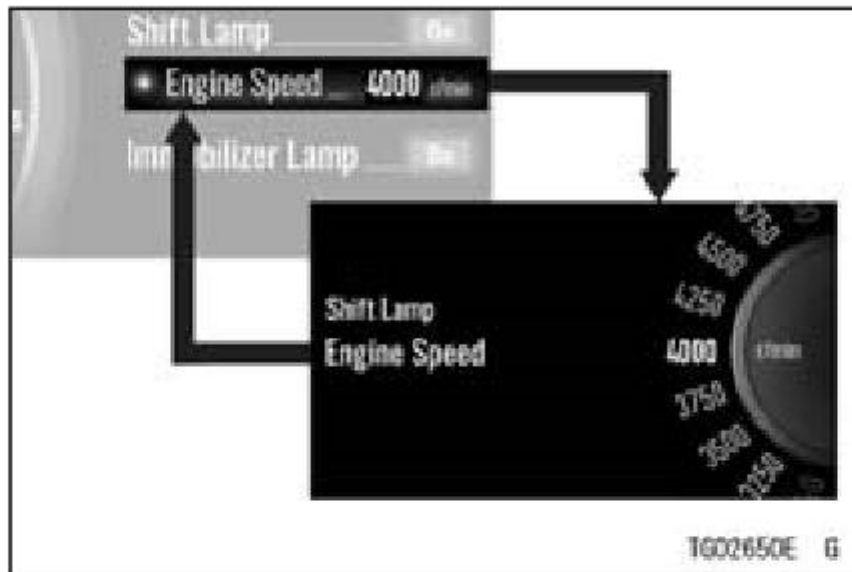

➔ : Flow when pushing the right meter button

## Immobilizer Lamp

This switches the immobilizer warning indicator blinking mode on or off.

- Highlight "Immobilizer Lamp" using the left meter button.
- Push the right meter button to shift to the next screen.
- Choose on or off using the left meter button.

- Push the right meter button.

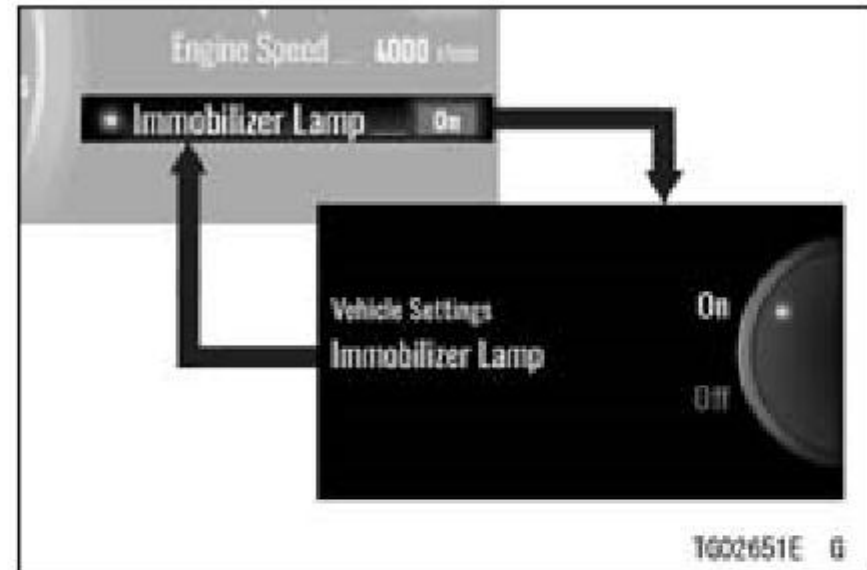

➔ : Flow when pushing the right meter button

## NOTE

- Refer to the Indicators section for details of the immobilizer warning indicator blinking mode.

## 70 GENERAL INFORMATION

### Display

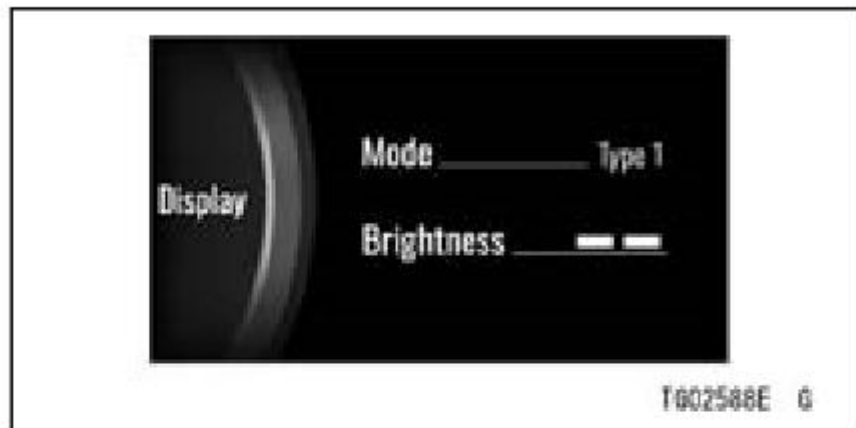

**Mode:** Switch layout of LCD

**Brightness:** Adjust backlight of LCD

- Enter the menu mode.
- Highlight “Display” using the left meter button.
- Push the right meter button to shift to the next screen.

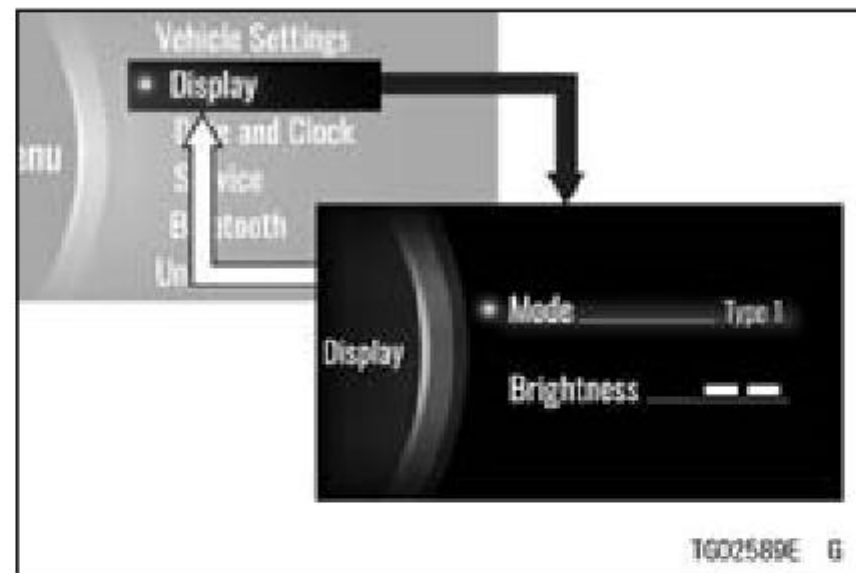

➔ : Flow when pushing the right meter button

➞ : Flow when pushing and holding the right meter button

### Mode

This switches the display layout.

- Highlight “Mode” using the left meter button.
- Push the right meter button to shift to the next screen.
- Choose “Type 1” or “Type 2” using the left meter button.



- Push the right meter button.

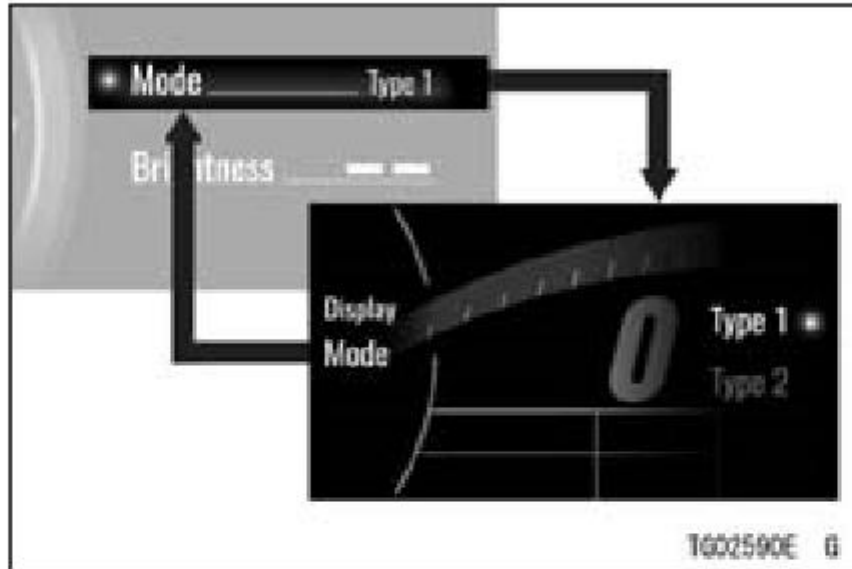

➔ : Flow when pushing the right meter button

### Brightness

This adjusts the backlight brightness of the screen in two levels.

- Highlight “Brightness” using the left meter button.

- Push the right meter button to shift to the next screen.
- Adjust the setting using the left meter button.
- Push the right meter button.

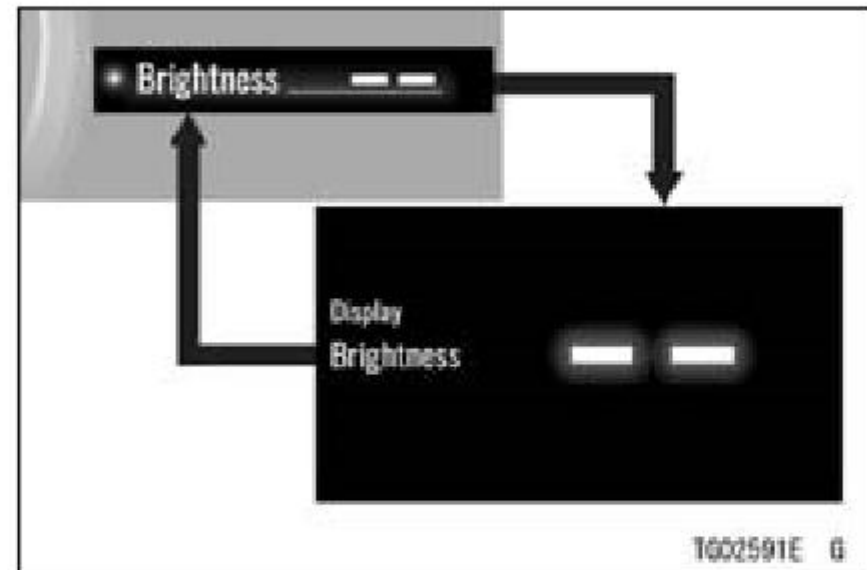

➔ : Flow when pushing the right meter button

## 72 GENERAL INFORMATION

### *Date and Clock*

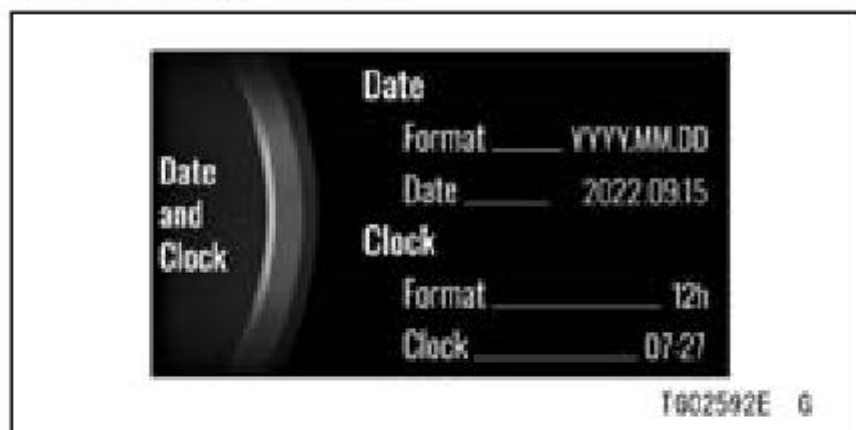

**Date:** Adjust date

**Clock:** Adjust clock

**Format:** Choose date and time notation

- Enter the menu mode.
- Highlight "Date and Clock" using the left meter button.
- Push the right meter button to shift to the next screen.

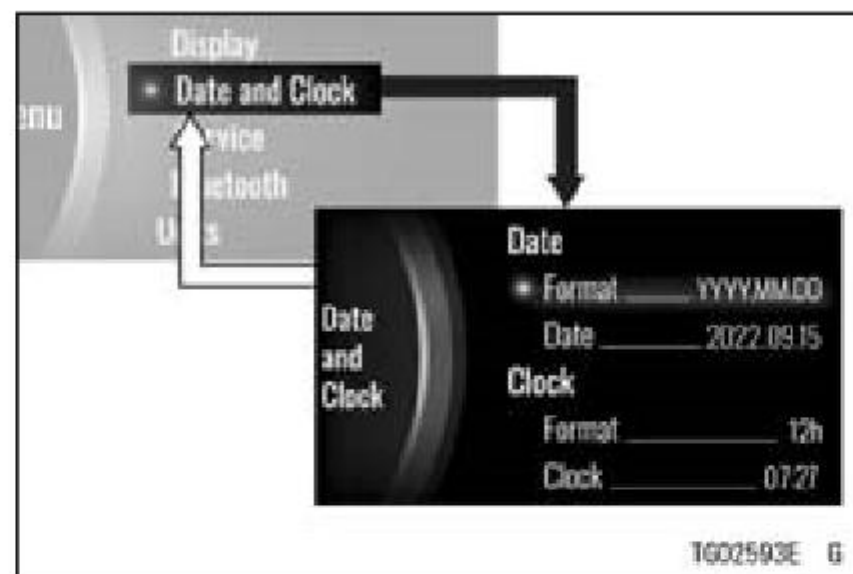

➡ : Flow when pushing the right meter button

⇨ : Flow when pushing and holding the right meter button

### **Format (Date)**

This switches the date format.

- Highlight "Format" under "Date" using the left meter button.
- Push the right meter button to shift to the next screen.
- Choose the date format using the left meter button.

- Push the right meter button.

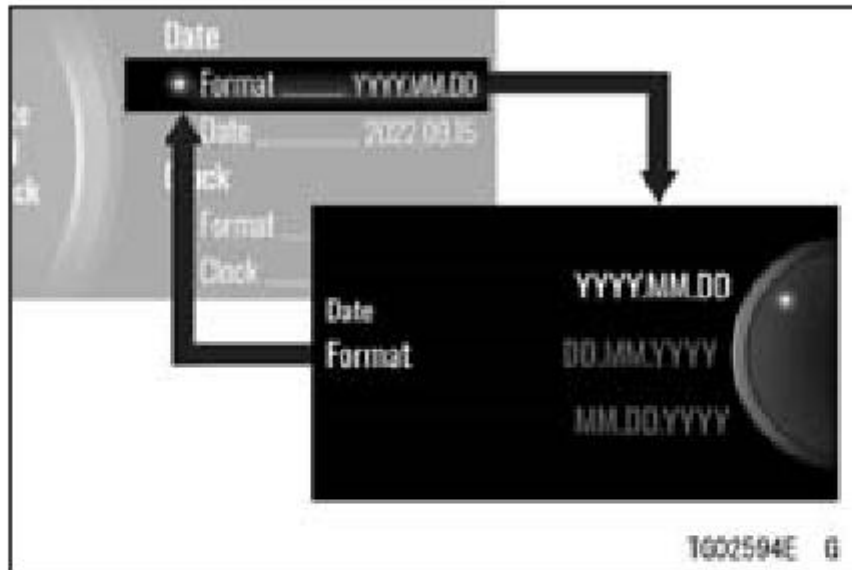

➔ : Flow when pushing the right meter button

### Date

- Highlight “Date” using the left meter button.
- Push the right meter button to shift to the next screen.
- Adjust the date using the left meter button.
- Push the right meter button.

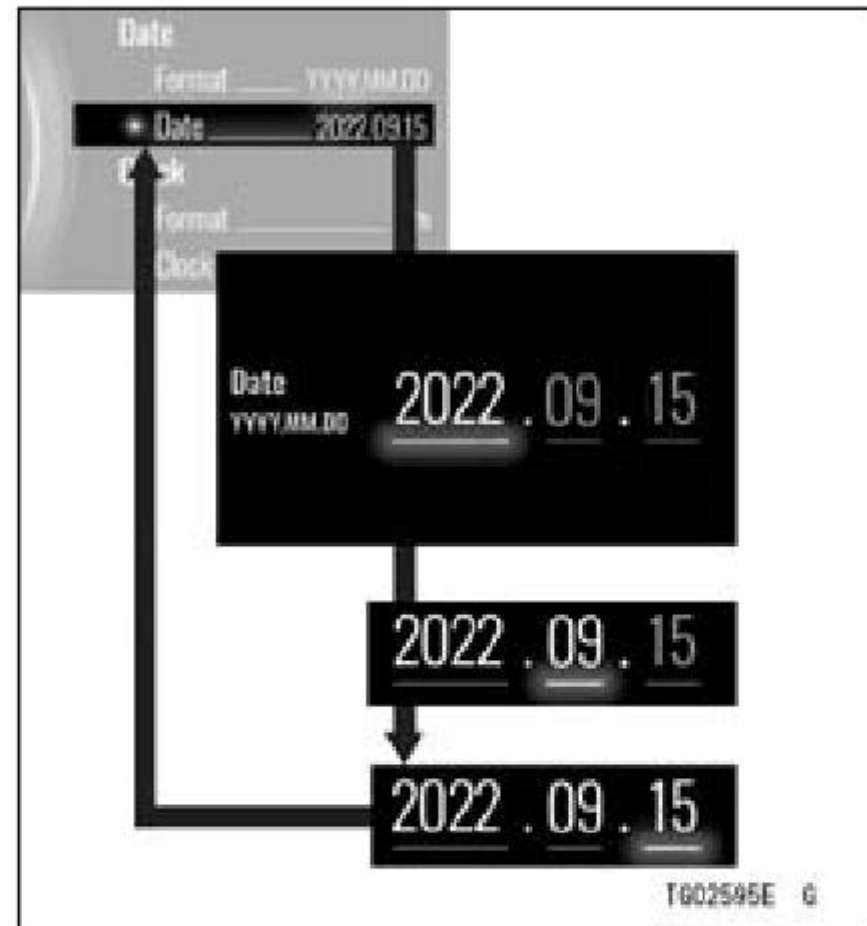

➔ : Flow when pushing the right meter button

### Format (Clock)

This switches the time display.

## 74 GENERAL INFORMATION

- Highlight “Format” under “Clock” using the left meter button.
- Push the right meter button to shift to the next screen.
- Choose the 12-hour clock or 24-hour clock using the left meter button.
- Push the right meter button.

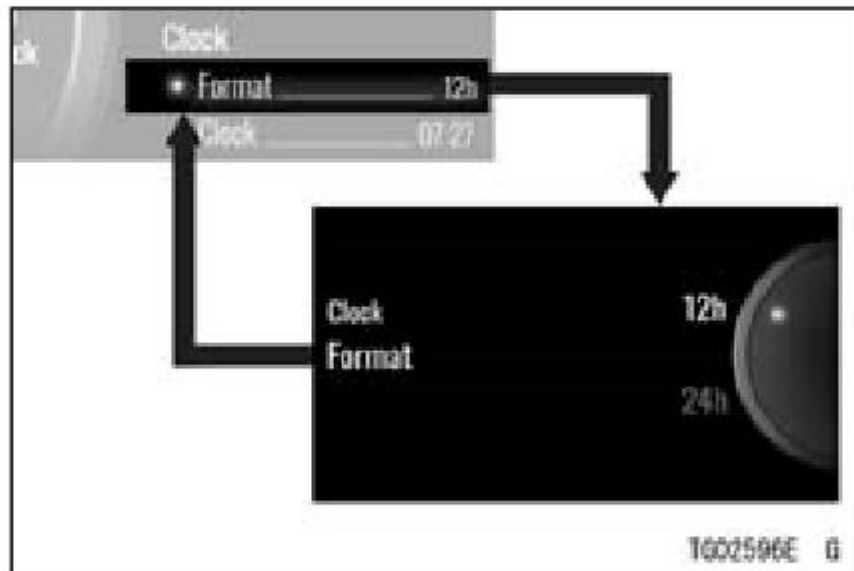

➔ : Flow when pushing the right meter button

### Clock

- Highlight “Clock” using the left meter button.
- Push the right meter button to shift to the next screen.
- Adjust the clock using the upper or lower left meter button.
- Push the right meter button.

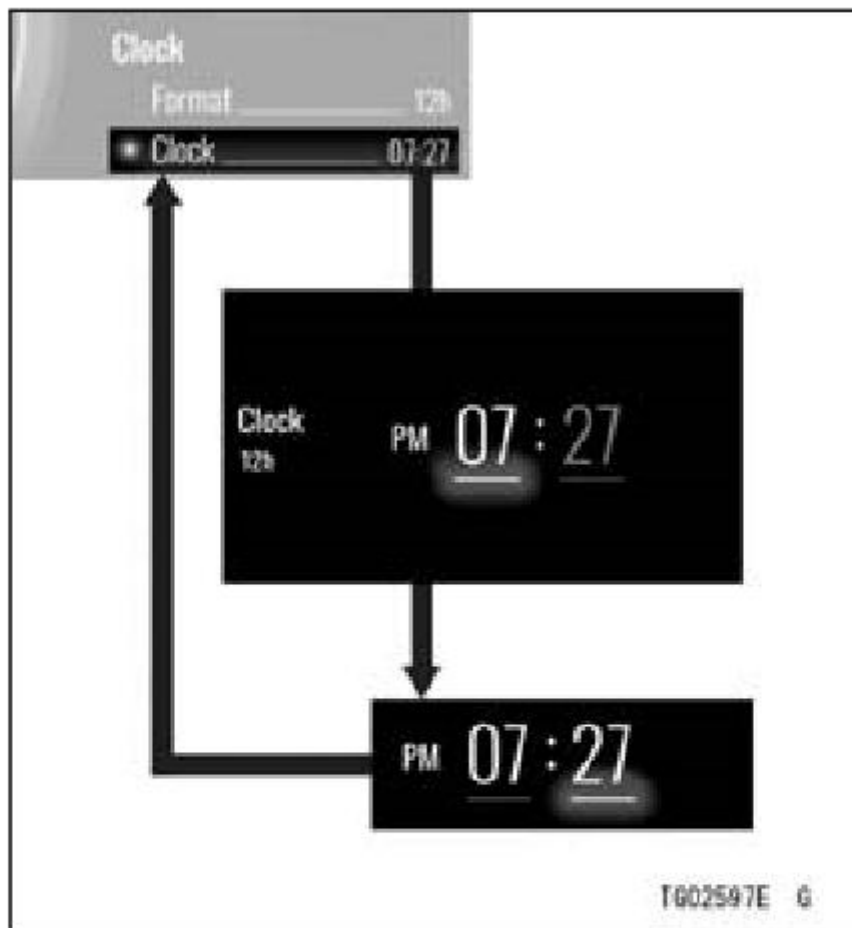

➡ : Flow when pushing the right meter button

## Service Screen 1 of 2

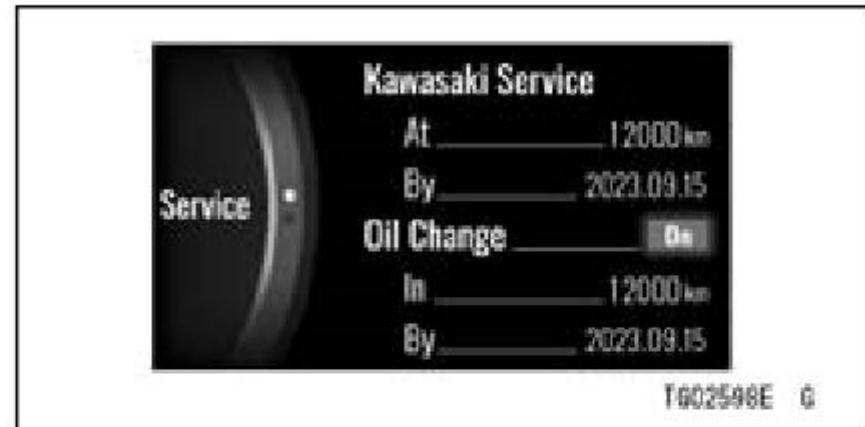

**Kawasaki Service:** Dealer defined interval for periodic maintenance (can be activated or deactivated by authorized Kawasaki dealer)

**Oil Change:** User defined interval for engine oil change (user can set distance and end date maintenance reminder)

## 76 GENERAL INFORMATION

### Screen 2 of 2

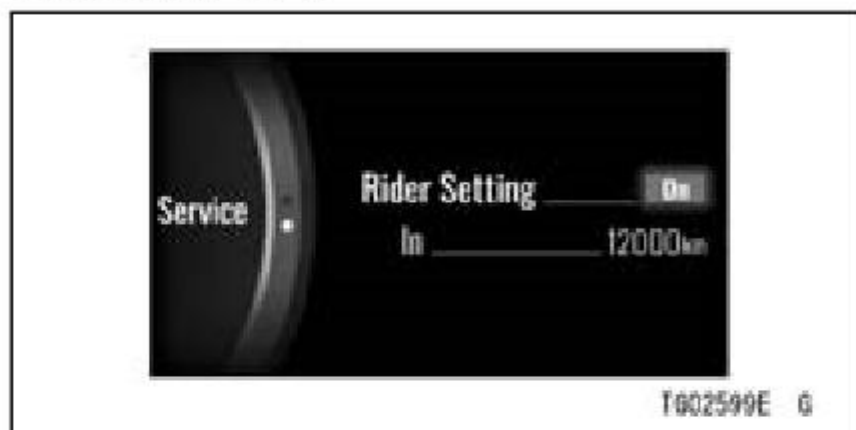

**Rider Setting:** User defined interval for maintenance (user can set distance maintenance reminder)

### NOTE

- *The disabled item is grayed out.*
- *The distance shown on the meter indicates the remaining distance to the maintenance reminder and will decrease as the vehicle is operated.*
- *The service item changes to orange when the scheduled date or distance is reached.*

- Enter the menu mode.
- Highlight “Service” using the left meter button.
- Push the right meter button to shift to the next screen.

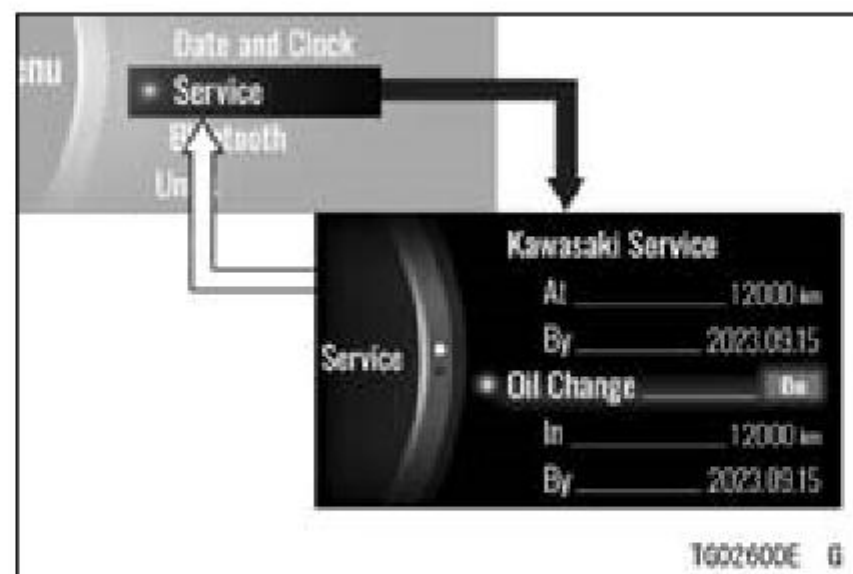

## Oil Change

This switches the maintenance schedule notification on or off. The setting distance also can be adjusted.

- Highlight “Oil Change” using the left meter button.
- Push the right meter button to shift to the next screen.
- Choose on or off using the left meter button.
- Push the right meter button.

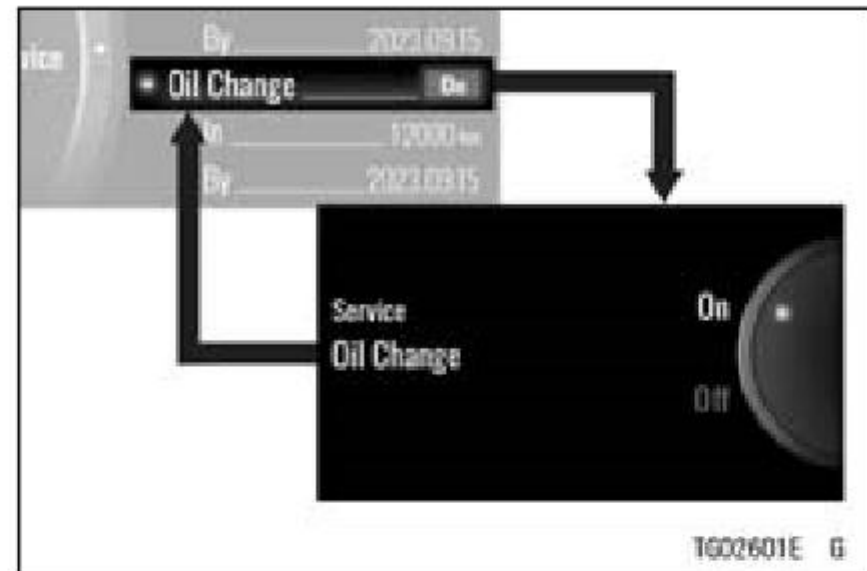

➔ : Flow when pushing the right meter button

- Highlight “In” under “Oil Change” using the left meter button.
- Push the right meter button to shift to the next screen.
- Set the desired distance using the left meter button.
- Push the right meter button.

## 78 GENERAL INFORMATION

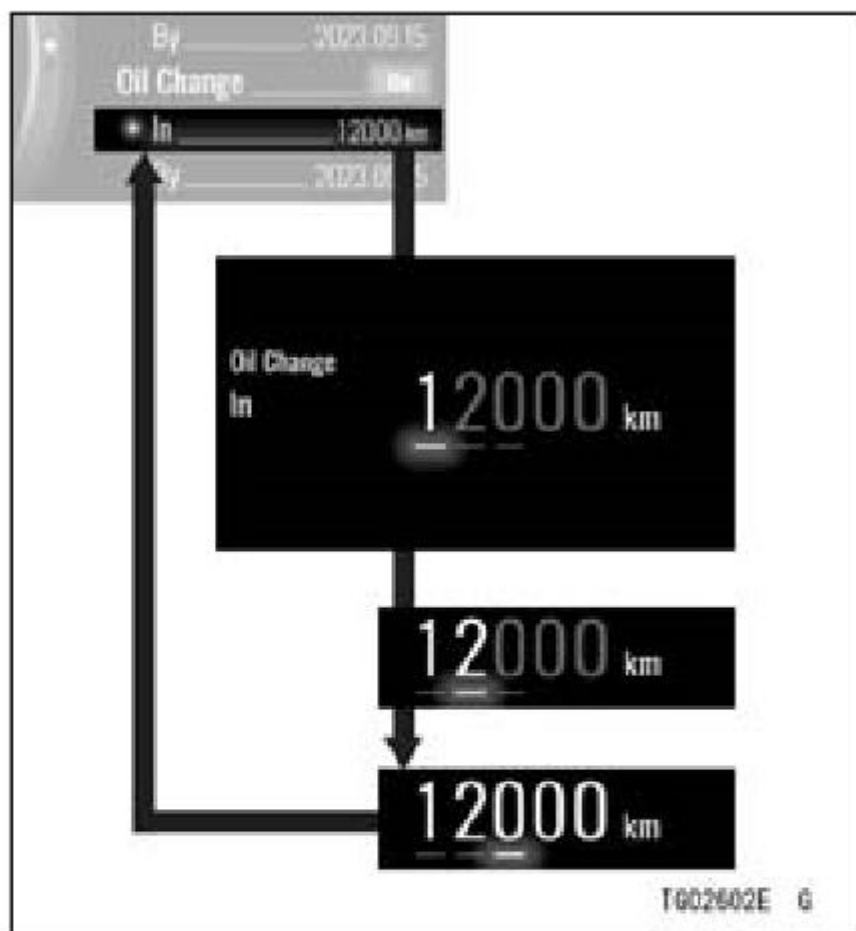

➡ : Flow when pushing the right meter button

## NOTE

- The setting date cannot be changed manually. It sets to one year later automatically when turning on this function or changing the distance. For example, when the current date is “2022.09.15,” it sets to “2023.09.15.”



## Rider Setting

This allows the rider to set the distance for certain maintenance item.

- Highlight “Rider Setting” using the left meter button.
- Push the the right meter button to shift to the next screen.
- Choose on or off using the left meter button.



- Push the right meter button.

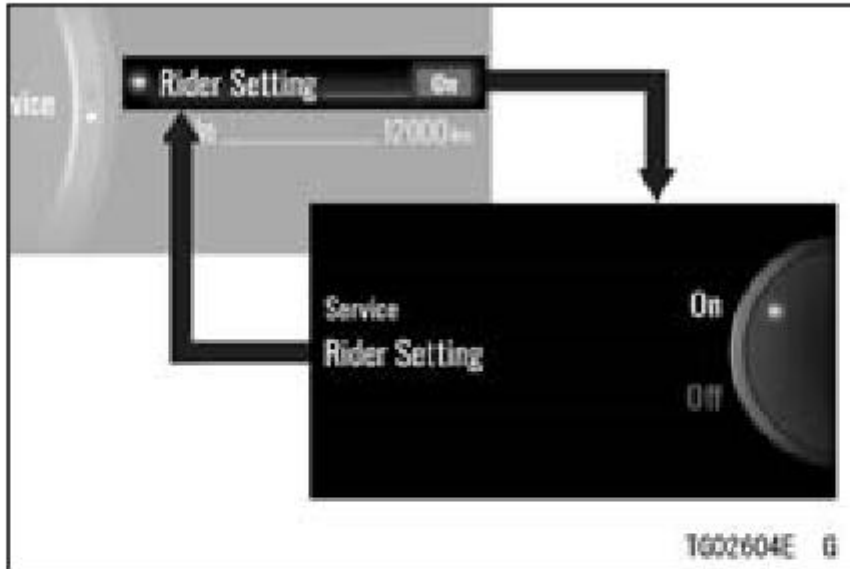

➔ : Flow when pushing the right meter button

- Highlight “In” under “Rider Setting” using the left meter button.
- Push the right meter button to shift to the next screen.
- Set the desired distance using the left meter button.

- Push the right meter button.

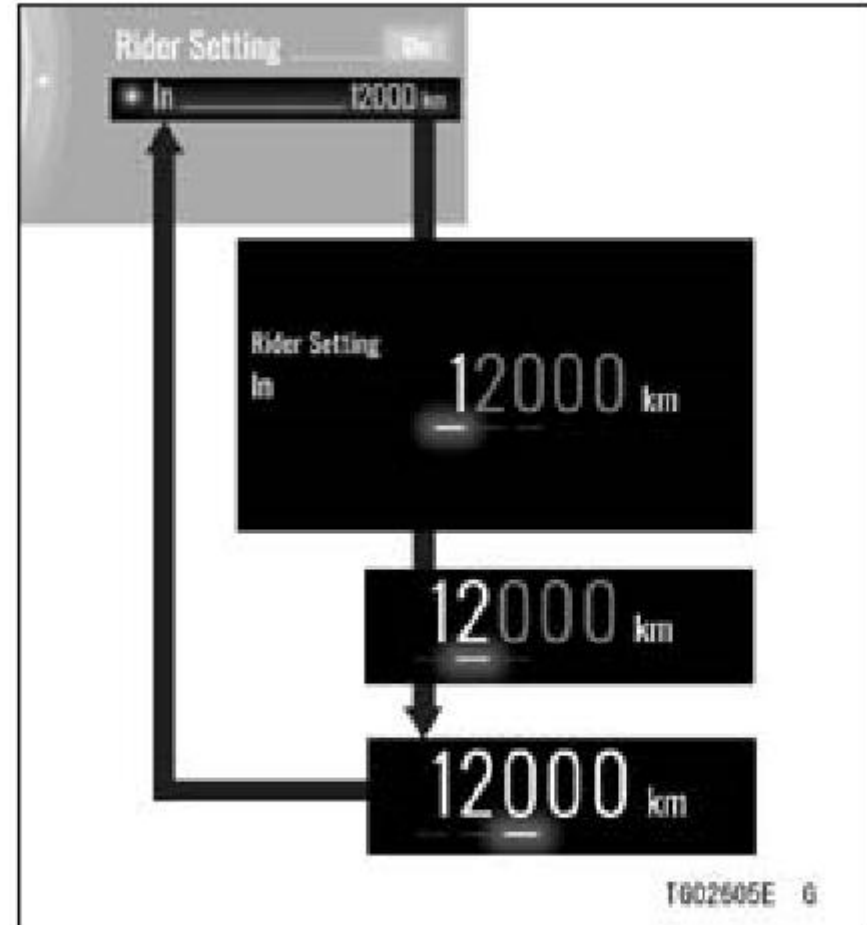

➔ : Flow when pushing the right meter button

## Bluetooth®

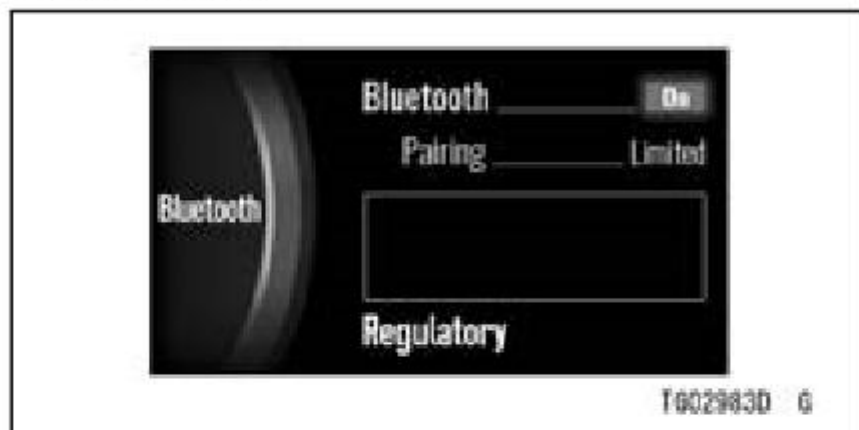

**Bluetooth:** Turn Bluetooth wireless technology on or off

**Pairing:** Switch pairing mode of Bluetooth

**Regulatory:** Display the acquired certification mark

### NOTE

○ To use the Bluetooth function, “RIDE-  
OLOGY THE APP” is necessary.

- Enter the menu mode.

- Highlight “Bluetooth” using the left meter button.
- Push the right meter button to shift to the next screen.

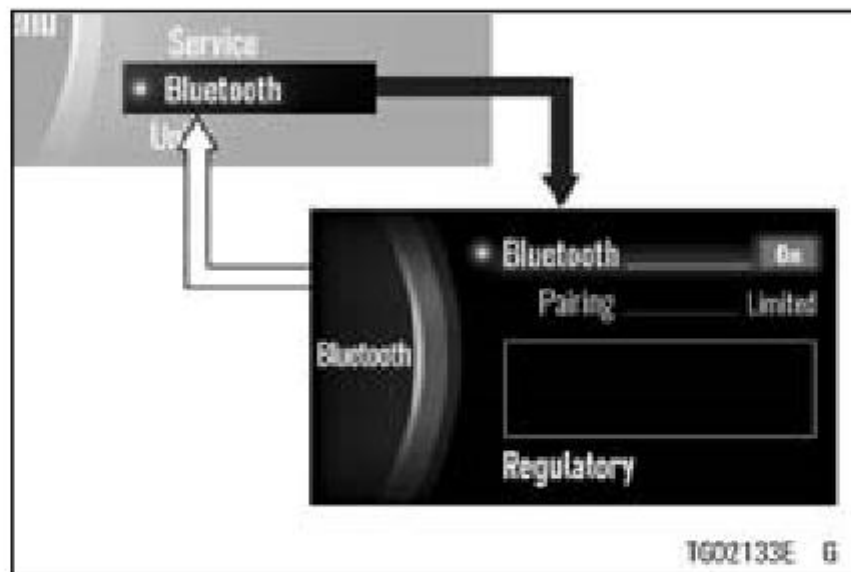

➡ : Flow when pushing the right meter button

↩ : Flow when pushing and holding the right meter button

## Bluetooth

This switches the Bluetooth on or off.

- Highlight “Bluetooth” using the left meter button.
- Push the right meter button to shift to the next screen.
- Choose on or off using the left meter button.
- Push the right meter button. When selecting “On,” the motorcycle starts searching for the smart device.
- Turn on the Bluetooth function of the smart device and launch the app.

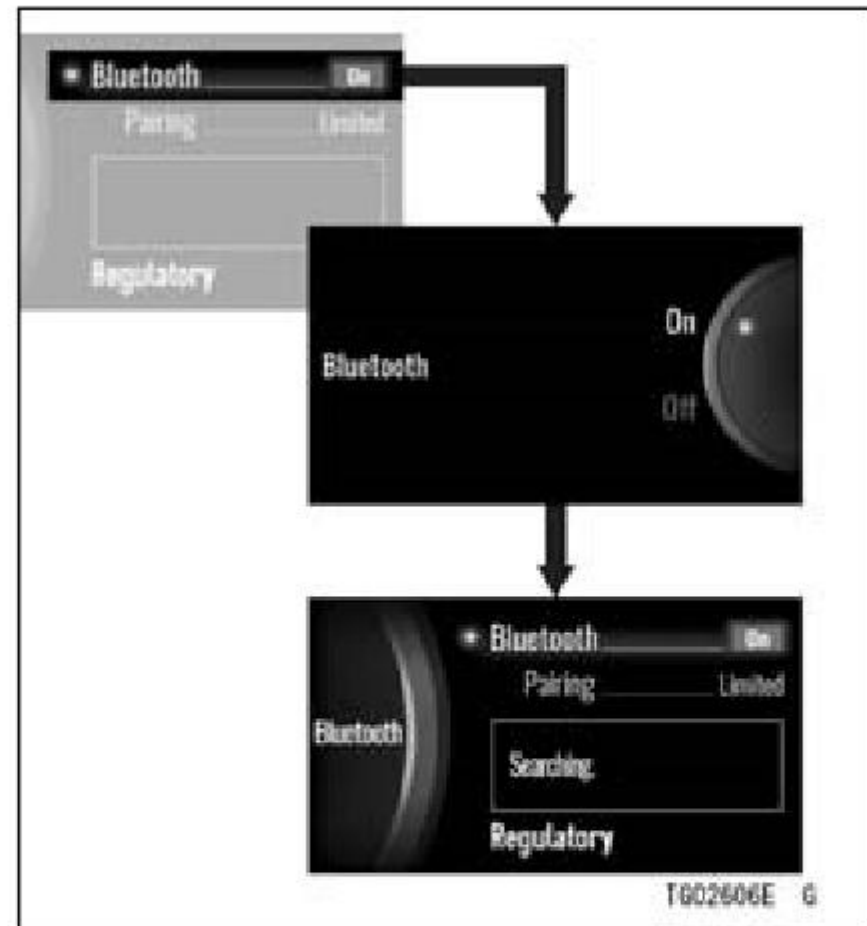

➔ : Flow when pushing right meter button

### NOTE

- If the motorcycle detects the paired device, they connect automatically.

## 82 GENERAL INFORMATION

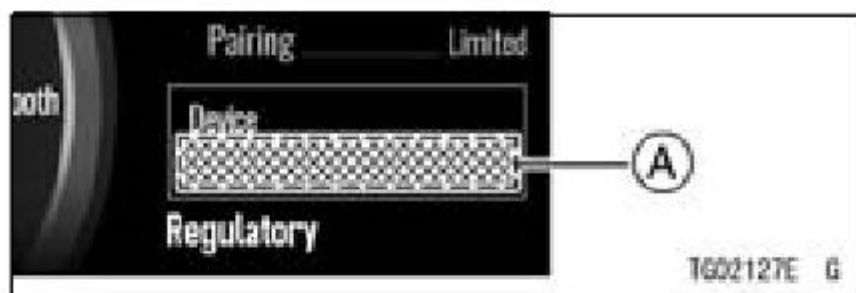

A. Connected Device Name

### NOTE

- *If the motorcycle does not have the paired device, it switches the pairing mode to "Open" automatically.*

### Pairing

This switches the pairing mode of Bluetooth. "Limited" is used when communication with the paired device.

"Open" can establish the communication with a new device.

- Highlight "Pairing" using the left meter button.
- Push the right meter button to shift to the next screen.
- Choose "Limited" or "Open" using the left meter button. When selecting "Open", the motorcycle start searching for an unpaired device.
- Turn on the Bluetooth function of the unpaired device and launch the app.

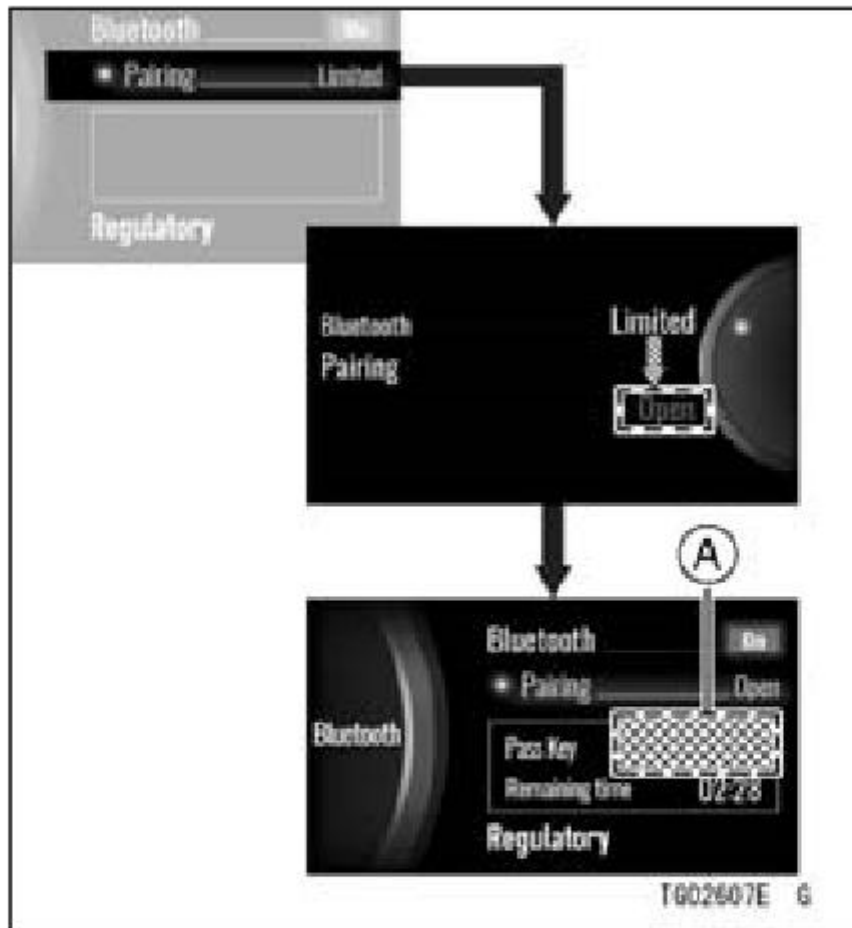

➡ : Flow when pushing right meter button  
 ➡ : Flow when pushing left meter button

**A. Pass Key (PIN)**

- In the pairing setting menu of the app, select “Ninja ZX-4R” and tap the connect button. The motorcycle displays the pass key (PIN) on the display screen.
- Enter the pass key (PIN) into the unpaired device.

**NOTE**

- *If the motorcycle does not detect the device, bring the device closer to the meter instruments.*

**Regulatory**

- Highlight “Regulatory” using the left meter button.
- Push the right meter button to shift to the next screen.
- Push the right meter button.

## 84 GENERAL INFORMATION

### Units

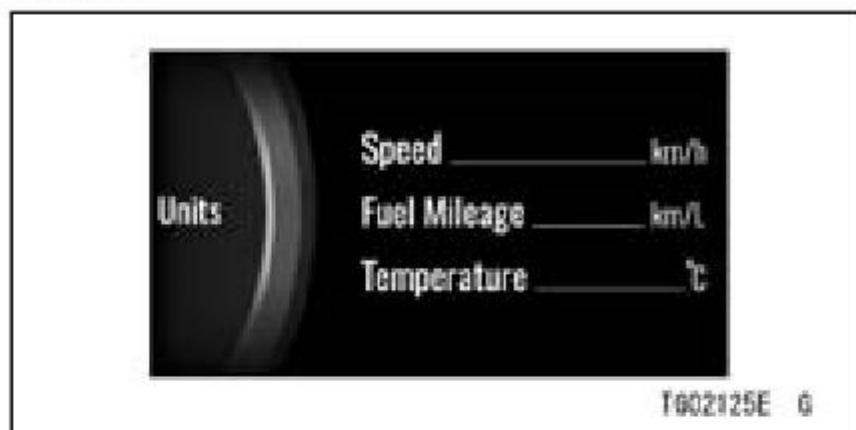

**Speed:** Switch unit of speed between km/h and mph

**Fuel Mileage:** Switch unit of fuel consumption

**Temperature:** Switch unit of temperature between °C and °F

- Enter the menu mode.
- Highlight "Units" using the left meter button.
- Push the right meter button to shift to the next screen.

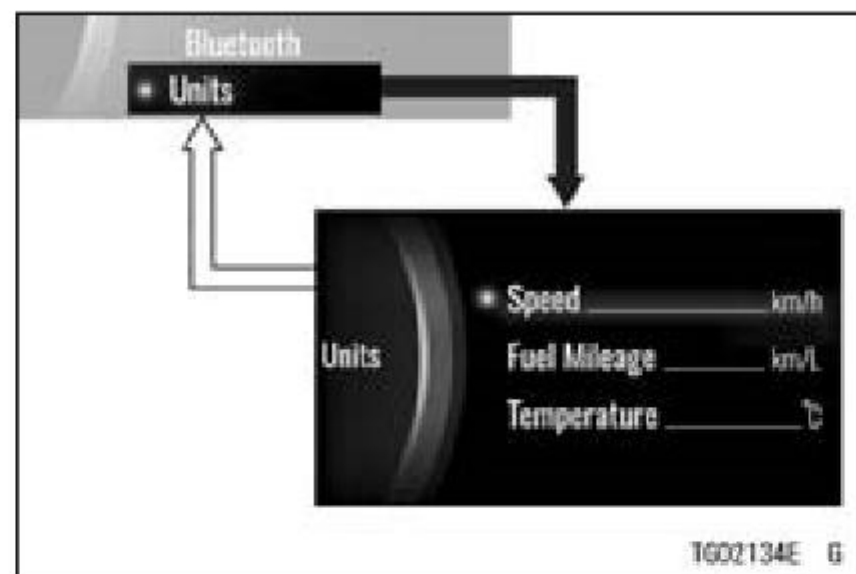

➔ : Flow when pushing the right meter button

⇨ : Flow when pushing and holding the right meter button

### Speed

This switches the unit of speed.

- Highlight "Speed" using the left meter button.
- Push the right meter button to shift to the next screen.
- Choose "km/h" or "mph" using the left meter button.

- Push the right meter button.

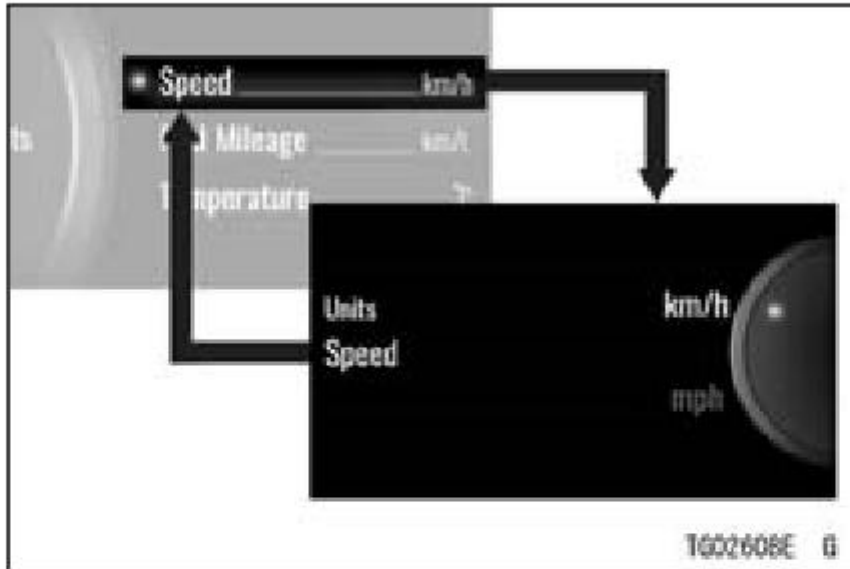

➔ : Flow when pushing the right meter button

### Fuel Mileage

This switches the unit of fuel consumption.

- Highlight “Fuel Mileage” using the left meter button.
- Push the right meter button to shift to the next screen.

- Choose the unit using the left meter button.
- Push the right meter button.

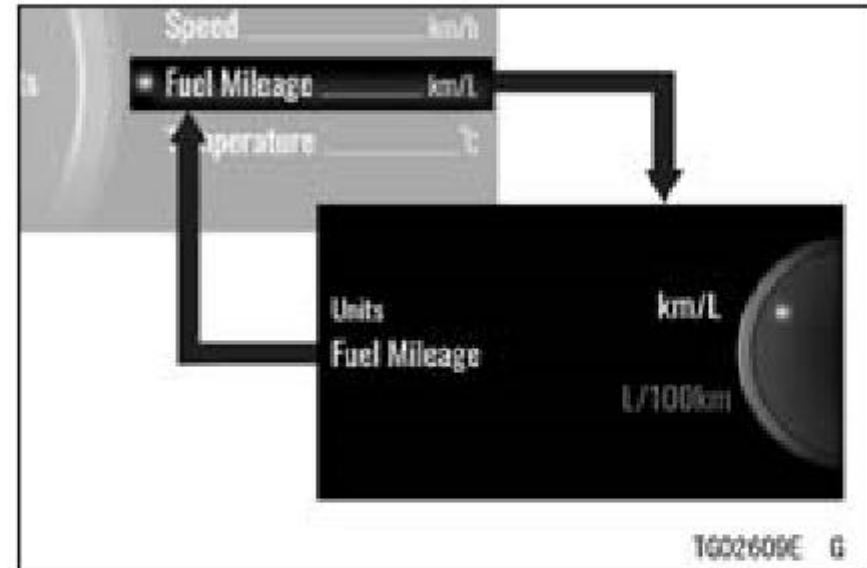

➔ : Flow when pushing the right meter button

### NOTE

- *The choices will change according to the unit set by “Speed.”*

### Temperature

This switches the unit of temperature.

## 86 GENERAL INFORMATION

- Highlight “Temperature” using the left meter button.
- Push the right meter button to shift to the next screen.
- Choose “°C” or “°F” using the left meter button.
- Push the right meter button.

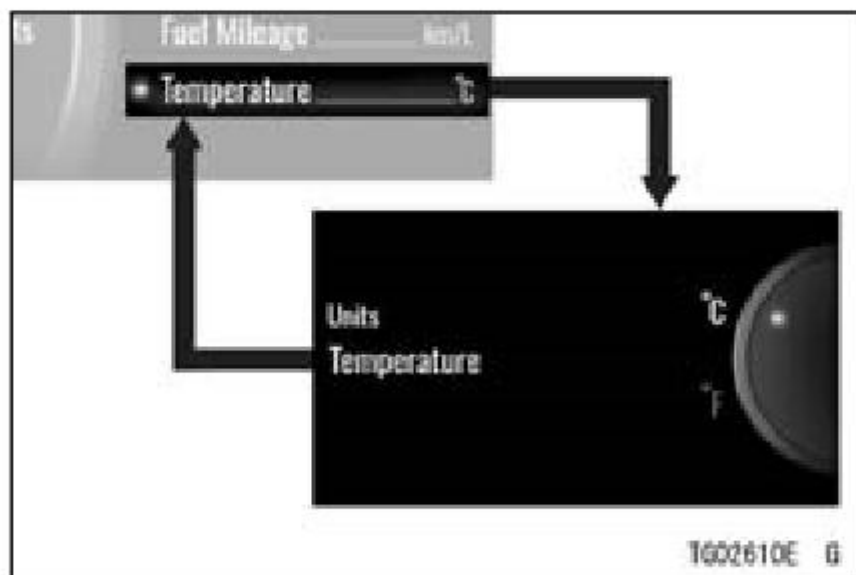

➔ : Flow when pushing the right meter button

## Stopwatch

(Only on display layout Type 2)



- A. Measurement Display
- B. Information Display

### Measurement Display

This stopwatch can record up to 99 lap times.

- Switch the display layout to the type 2 (see Menu Mode section).
- Push the LAP button. The stopwatch starts timing.



- Push the LAP button while timing, the previous lap time is displayed for 10 seconds. The lap time is recorded each time the LAP button is pushed.

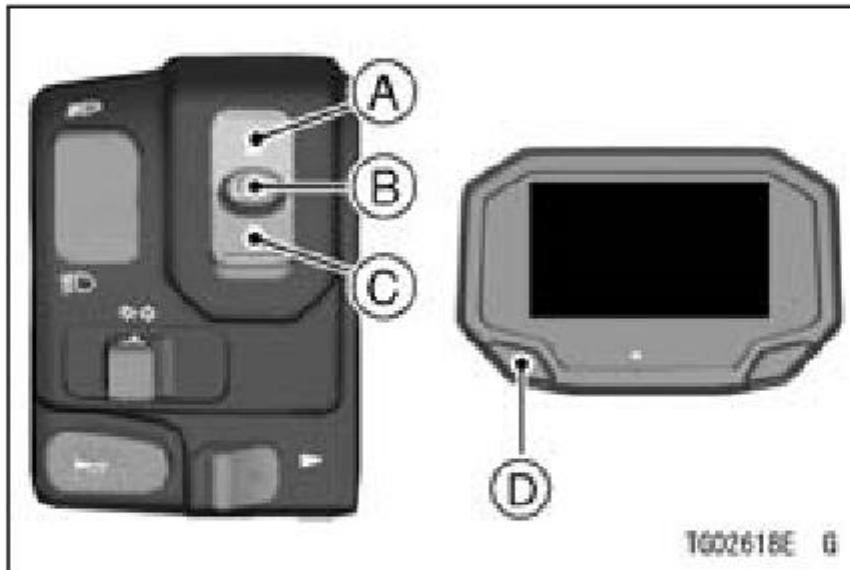

- A. Upper Button
- B. LAP Button
- C. Lower Button
- D. Left Meter Button

**NOTE**

- The stopwatch is counting continuously while showing the previous lap

time. While the previous lap time is displayed, push the LAP button to switch to the current lap time.

- Up to 99 lap times can be stored and the excess is not recorded.
- Push and hold the LAP button. The stopwatch stops.

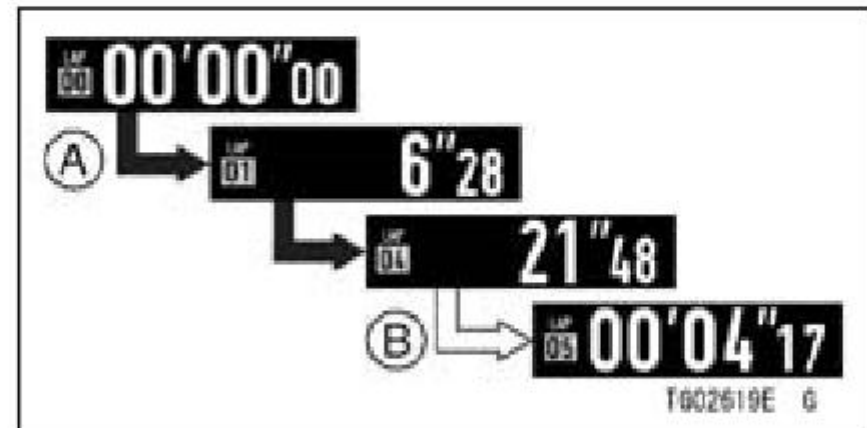

- ➡ : Flow when pushing LAP button
- ↪ : Flow when pushing and holding the LAP button

- A. Timing starts
- B. Timing stops

- Push the upper or lower button while stopping the stopwatch. The display

## 88 GENERAL INFORMATION

is switched each time the upper or lower button is pushed.

### NOTE

- The lap number "00" means the total time of all laps.

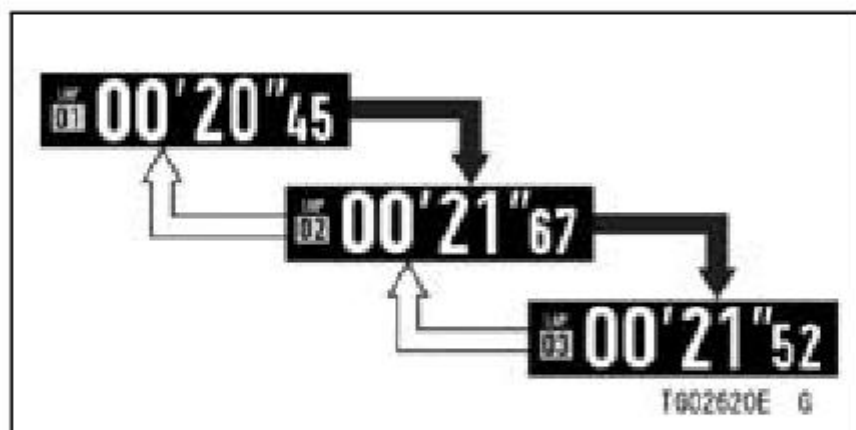

➡ : Flow when pushing upper button

↳ : Flow when pushing lower button

### How to reset

- Push and hold the left meter button while stopping the stopwatch.

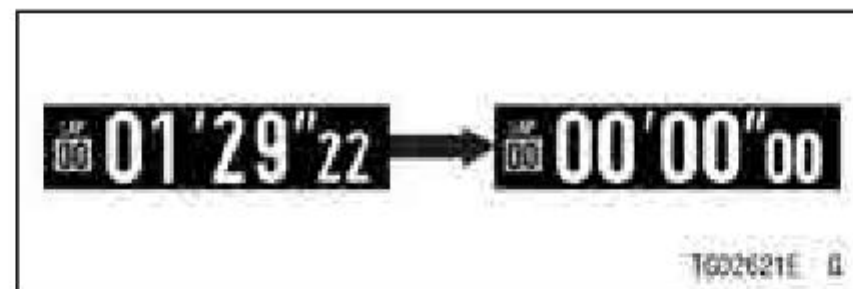

➡ : Flow when pushing and holding left meter button

### NOTE

- All records are not deleted even if the ignition switch is turned off.

### Information Display

- The information display can be changed by pressing the right meter button.

### NOTE

- The display cannot be changed while timing or in case of the lap time record remains.

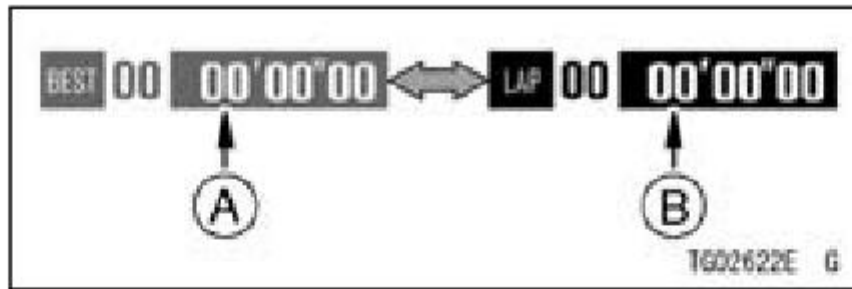

⇒ : Flow when pushing right meter button  
 A. Best Lap  
 B. Last Lap

- Push the LAP button while timing, the information display shows the time difference from the best lap for 10 seconds.

### NOTE

- For the first lap, the information display show the time difference from before timing.

- After 10 seconds, the time difference display switches to the best lap or last lap.

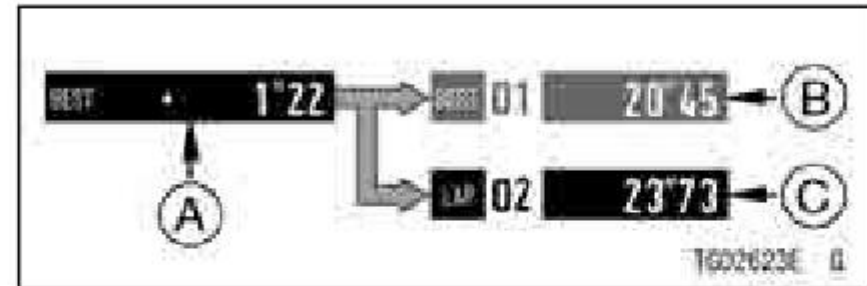

A. Time Differences  
 B. Best Lap  
 C. Last Lap

### Keys

You will need the key number or spare key to have a duplicate made.

## 90 GENERAL INFORMATION

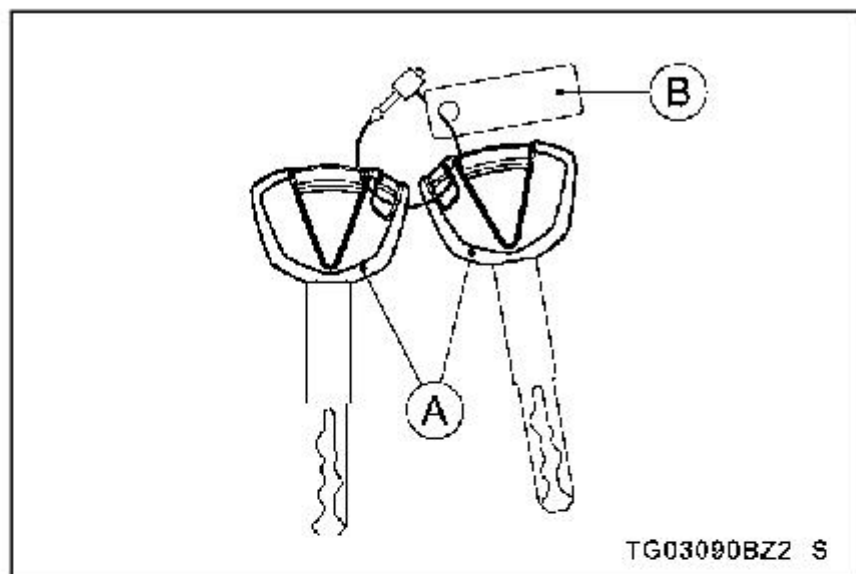

- A. Ignition Key
- B. Key Number Tag

If you lose all keys and the key number, you will need to replace the ignition switch and all other locks operated by that key.

Contact your Kawasaki dealer to purchase additional spare keys.

## Ignition Switch/Steering Lock

This is a three-position, key-operated switch.

The key can be removed when it is in the "OFF" or "LOCK" position.

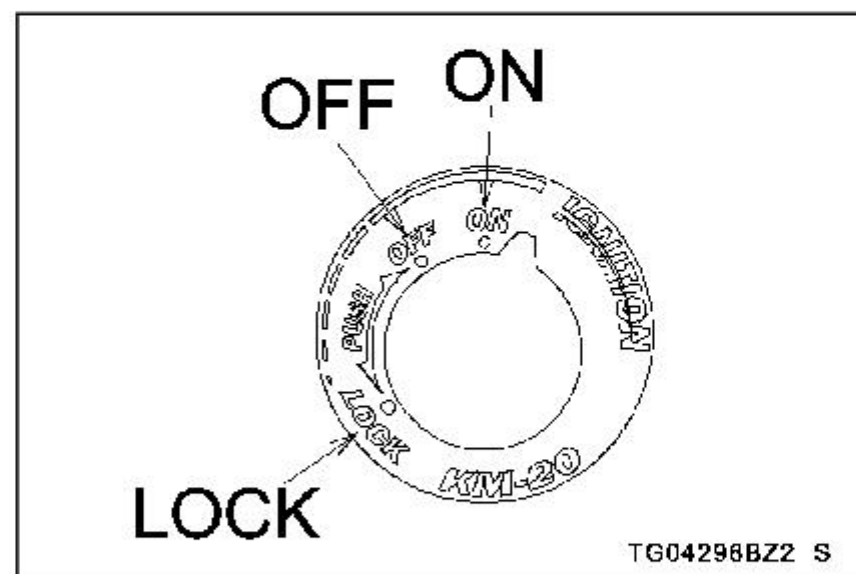

<b>ON</b>	<ul style="list-style-type: none"> <li>● Engine can be started.</li> <li>● All electrical equipment can be used.</li> <li>● Key cannot be removed.</li> </ul>
<b>OFF</b>	<ul style="list-style-type: none"> <li>● Engine off.</li> <li>● Electrical equipment is off.</li> <li>● Key can be removed.</li> </ul>
<b>LOCK</b>	<ul style="list-style-type: none"> <li>● Steering locked.</li> <li>● Engine off.</li> <li>● Electrical equipment is off.</li> <li>● Key can be removed.</li> </ul>

For locking:

1. Turn the handlebars fully to the left.
2. Push the key down in the "OFF" position and turn it to "LOCK".

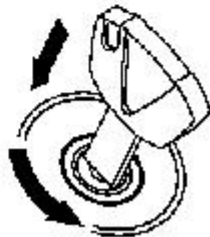

1G04227B 5

## ⚠ **WARNING**

**Turning the ignition switch to the OFF position while riding the motorcycle shuts down the entire electrical system (headlight, brake light, turn signal light, etc.) and the engine will stop, which could cause an accident resulting in severe injury or death. Never operate the ignition switch while riding the motorcycle; only operate it when the motorcycle is at a standstill.**

## **NOTE**

- *The headlight, tail, city and license plate lights are on whenever the ignition key is in the "ON" position.*
- *Do not leave the ignition switch at the "ON" position for an extended time with the engine stopped, or the battery may become totally discharged.*

## 92 GENERAL INFORMATION

- Do not leave the hazard lights switched on for a long time without the engine running or the battery will become discharged.

### Right Handlebar Switches

#### NOTE

- Do not put any magnet close to the right switch housing. It may affect the electronic throttle sensor.

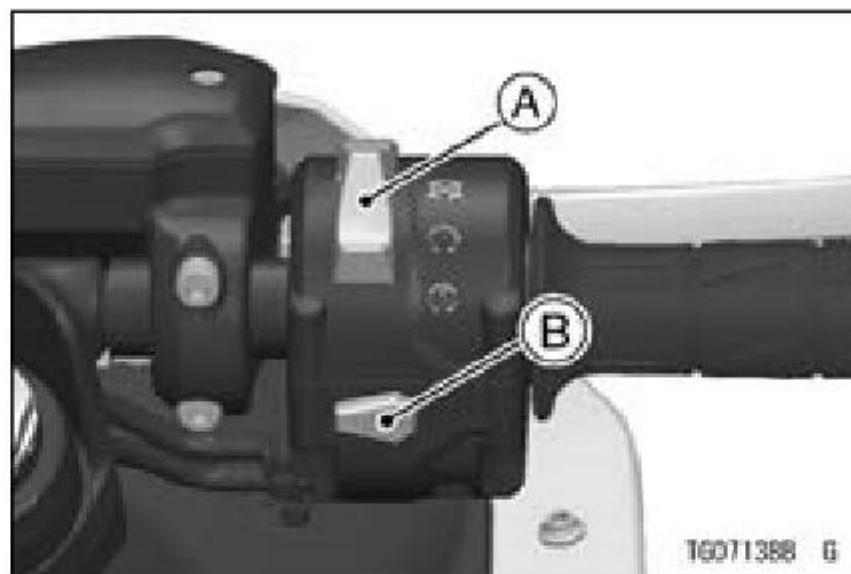

- A. Engine Start/Stop Switch
- B. SELECT Button

### **Engine Start/Stop Switch**

To start the engine, refer to the Starting the Engine section for starting instructions.

To stop the engine in an emergency, move the engine stop switch to the  position.

Ordinarily, the engine stop switch must be in the  position for the motorcycle to operate.

**NOTE**

- Ordinarily, the ignition switch should be used to stop the engine.
- Although the engine stop switch stops the engine, it does not turn off all the electrical circuits and eventually the battery will be discharged.

**SELECT Button**

The SELECT button is used for setting the RIDER mode parameters and KQS mode.

RIDER mode parameter setting:	Refer to the Integrated Riding Modes section in the HOW TO RIDE THE MOTORCYCLE chapter.
KQS mode setting:	Refer to the KQS section in the HOW TO RIDE THE MOTORCYCLE chapter.

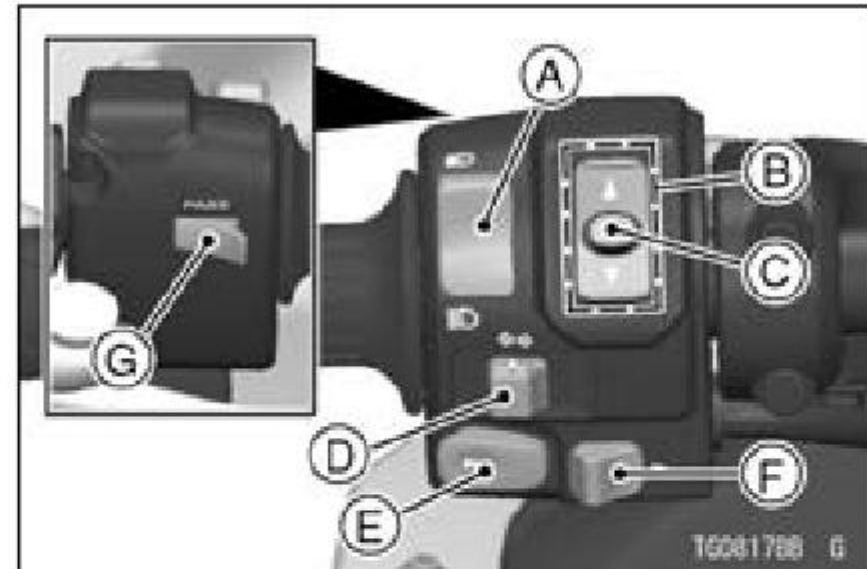
**Left Handlebar Switches**

- A. Dimmer Switch
- B. Multifunction Button
- C. LAP Button
- D. Turn Signal Switch
- E. Horn Button
- F. Hazard Switch
- G. Passing Button

## 94 GENERAL INFORMATION

### **Dimmer Switch**

High or low beam can be selected with the dimmer switch.

High beam...  (High beam indicator: see Meter Instruments section)

Low beam... 

### **NOTE**

- *Do not allow anything to cover the headlight lens when the headlight is on. If covered, heat can build up in the headlight lens causing lens discoloration or melting, as well as damage to the item covering the lens.*

### **Multifunction Button**

The multifunction button is used for setting the meter, integrated riding mode and KQS mode.

Meter setting: Refer to the Multifunction Display section.

Riding mode: Refer to the Integrated Riding Modes section in the HOW TO RIDE THE MOTORCYCLE chapter.

KQS mode setting: Refer to the KQS section in the HOW TO RIDE THE MOTORCYCLE chapter.



### **LAP Button**

The LAP button is used for stopwatch start and stop.

Stopwatch start: Refer to the Stopwatch section.



**Turn Signal Switch**

When the turn signal switch is turned to the left (  ) or right (  ), the corresponding turn signal lights and turn signal indicator blinks. To cancel the turn signal, push the switch in.

**Horn Button** 

When the horn button is pushed, the horn sounds.

**Hazard Switch** 

Push in the hazard switch with the ignition switch in the “ON” position. All the turn signal lights and turn signal indicators will blink.

**NOTE**

○ *Be careful not to use the hazard lights for an extended period of time,*

*otherwise the battery may become totally discharged.*

**Passing Button** 

The high beam turns on only while the passing button is pushed.

**Brake Lever Adjuster**

While pushing the brake lever forward, rotate the adjuster and choose a suitable lever position from the five positions.

**[Brake Lever Adjustment]**

Adjuster Position	1	2	3	4	5
Lever Position	Far	←	—	→	Near

## 96 GENERAL INFORMATION

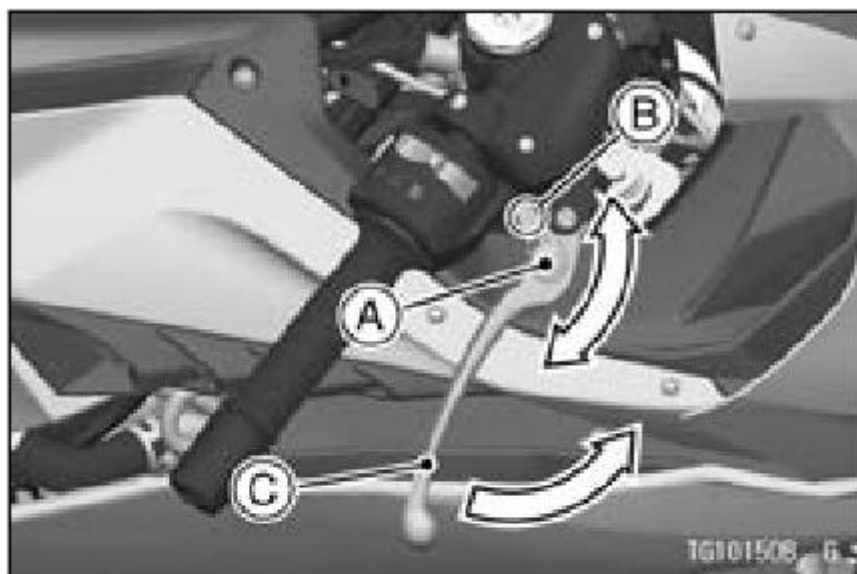

- A. Adjuster
- B. Mark
- C. Brake Lever

### Clutch Lever Adjuster

While pushing the clutch lever forward, rotate the adjuster and choose a suitable lever position from the five positions.

#### [Clutch Lever Adjustment]

Adjuster Position	1	2	3	4	5
Lever Position	Far ←	—	→	Near	

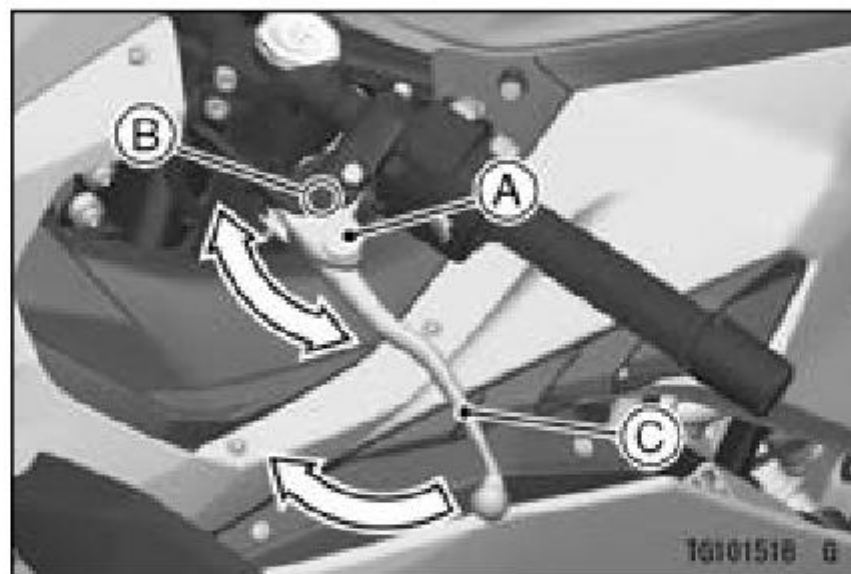

- A. Adjuster
- B. Mark
- C. Clutch Lever

## Fuel



### WARNING

Gasoline is extremely flammable and can be explosive under certain conditions, creating the potential for serious burns. Turn the ignition switch off.

Do not smoke.

Make sure the area is well ventilated and free from any source of flame or sparks; this includes any appliance with a pilot light.

---

## Fuel Requirements

---

Use clean, fresh unleaded gasoline with the following conditions.

- Antiknock Index of 87 or more
- Up to 10% of ethanol contained

### NOTICE

Use only unleaded gasoline. Never use leaded gasoline. Leaded gasoline significantly reduces the capability of the catalytic converter in the exhaust system.

### NOTICE

Use minimum of 87 octane gasoline only to prevent severe engine damage.

**NOTICE**

If engine “knocking” or “pinging” occurs, use a different brand of gasoline of a higher octane rating. If this condition is allowed to continue it can lead to severe engine damage. Gasoline quality is important. Fuels of low quality or not meeting standard industry specifications may result in unsatisfactory performance. Operating problems that result from the use of poor quality or nonrecommended fuel may not be covered under your warranty.

**NOTICE**

Avoid using blends of unleaded gasoline and methanol (wood alcohol) whenever possible, and never use “gasohol” containing more than 5% methanol. Fuel system damage and performance problems may result.

**NOTE**

- *Other oxygenates approved for use in unleaded gasoline include TAME (up to 16.7%) and ETBE (up to 17.2%). Fuel containing these oxygenates can also be used in your Kawasaki.*

**NOTICE**

**Never use gasoline with an octane rating lower than the minimum specified by Kawasaki. Never use “gasohol” with more than 10% ethanol, or more than 5% methanol.**

**Gasoline containing methanol must also be blended with cosolvents and corrosion inhibitors.**

**Certain ingredients of gasoline may cause paint fading or damage. Be extra careful not to spill gasoline or gasoline oxygenate blends during refueling.**

**When not operating your Kawasaki for 30 to 60 days, mix a fuel stabilizer (such as STA-BIL) with the gasoline in the fuel tank. Fuel stabilizer additives inhibit oxidation of the fuel which minimizes gummy deposits.**

***Fuel Type and Octane Rating***

Use clean, fresh unleaded gasoline.

The Antiknock Index is posted on service station pumps. The octane rating of a gasoline is a measure of its resistance to detonation or “knocking.” The Antiknock Index is an average of the Research Octane Number (RON) and the Motor Octane Number (MON) as shown in the table.

Fuel Type	Unleaded Gasoline
Ethanol Content	E10 or less
Antiknock Index	87 or more

## **NOTICE**

Do not use any fuel that contains more ethanol or other oxygenates than specified for E10 fuel\* in this vehicle. Damage to the engine and fuel system, or engine starting and/or performance problems may result from the use of improper fuel.

\*E10 means fuel containing up to 10% ethanol.

---

## **Filling the Tank**

---

Avoid filling the tank in the rain or where heavy dust is blowing so that the fuel does not get contaminated.

## **WARNING**

Gasoline is extremely flammable and can be explosive under certain conditions, creating the potential for serious burns. Turn the ignition switch off. Do not smoke.

Make sure the area is well ventilated and free from any source of flame or sparks; this includes any appliance with a pilot light. Never fill the tank completely to the top.

If the tank is filled completely to the top, heat may cause the fuel to expand and overflow through the vents in the tank cap.

After refueling, make sure the tank cap is closed securely. If gasoline is spilled on the fuel tank, wipe it off immediately.

**NOTICE**

Never fill the tank so the fuel level rises into the filler neck. If the tank is overfilled, heat may cause the fuel to expand and flow into the Evaporative Emission Control System resulting in hard starting, engine hesitation and non-compliance with the emission regulation.

- Lift the key hole cover.
- Insert the ignition key into the fuel tank cap.
- Turn the key clockwise while pushing down the fuel tank cap.

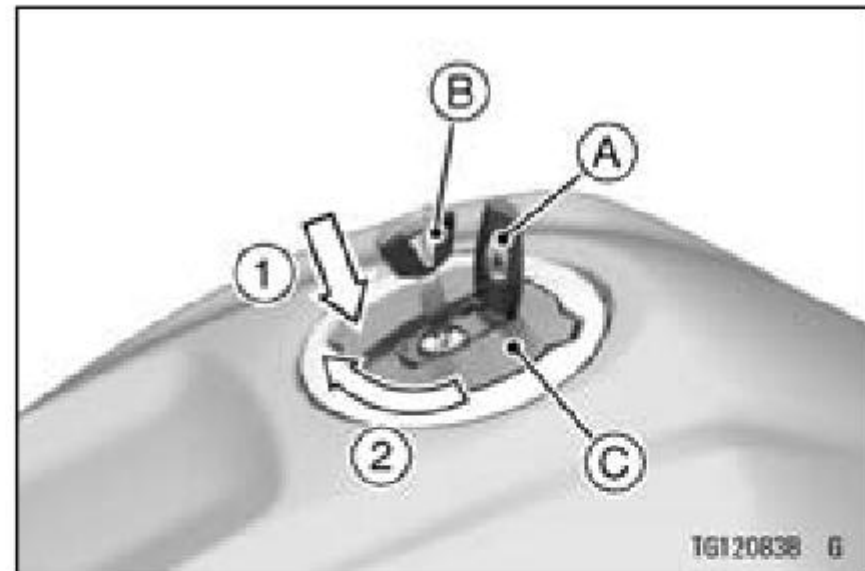

- A. Key Hole Cover
- B. Ignition Key
- C. Fuel Tank Cap

- Open the fuel tank cap.
- Add fuel.

## 102 GENERAL INFORMATION

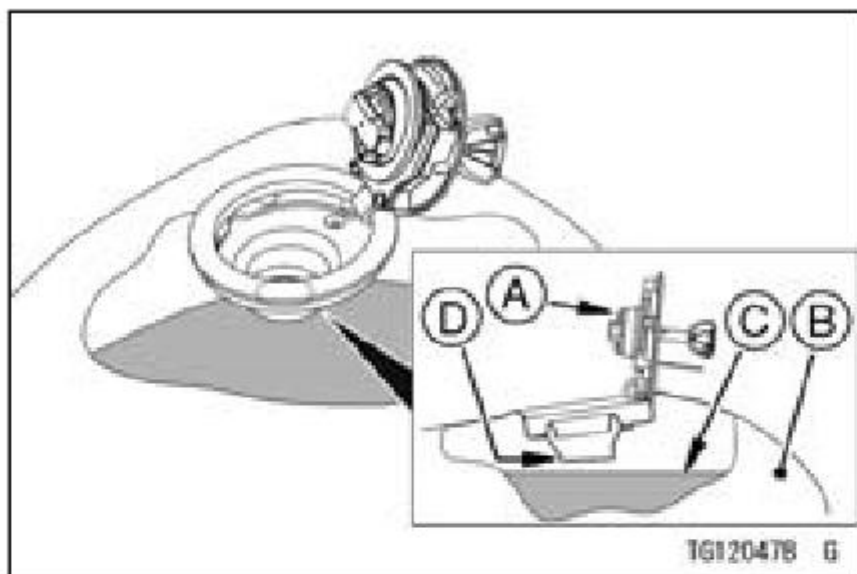

- A. Tank Cap
- B. Fuel Tank
- C. Top Level
- D. Bottom of Filler Neck (Maximum Fuel Level)

### NOTE

- *Do not exceed the maximum fuel level as shown.*
- Push the fuel tank cap down into place with the key inserted.

- The key can be removed by turning counterclockwise to the original position.
- Close the key hole cover.

### NOTICE

**Never fill the tank completely to the top.**  
**If the tank is filled completely to the top, heat may cause the fuel to expand and overflow through the vents in the tank cap.**  
**After refueling, make sure the tank cap is closed securely.**  
**If gasoline is spilled on the fuel tank, wipe it off immediately.**

### NOTE

- *The fuel tank cap cannot be closed without the key inserted, and the key*



*cannot be removed unless the cap is locked properly.*

- *Do not push on the key to close the cap, or the cap cannot be locked.*

## Side Stand

Always kick the stand fully up before moving the motorcycle. The engine will stop automatically if the motorcycle is in gear and the clutch is released with the side stand down.

### NOTE

- *When using the side stand, turn the handlebars to the left.*
- *Make sure the side stand is down securely before leaving the motorcycle.*

- *Do not sit on the motorcycle while it is on its side stand.*

## Seats

The seats can be removed by in order of the passenger's seat then the rider's seat.

### ***Passenger's Seat Removal***

- Insert the ignition key into the seat lock.
- Lift the front part of the passenger's seat upward while turning the key clockwise.
- Remove the passenger's seat forward.
- Remove the ignition key.

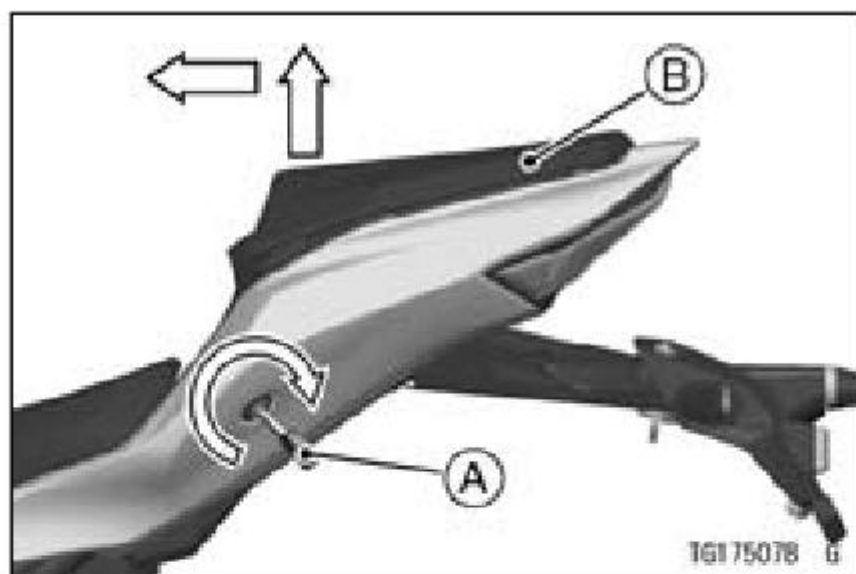

A. Ignition Key  
B. Passenger's Seat

### ***Passenger's Seat Installation***

- Insert the hooks at the rear of the passenger's seat into the slots of the frame.
- Insert the seat lock projection at the front of the passenger's seat into the latch hole.
- Push down the front part of the passenger's seat until the lock clicks.

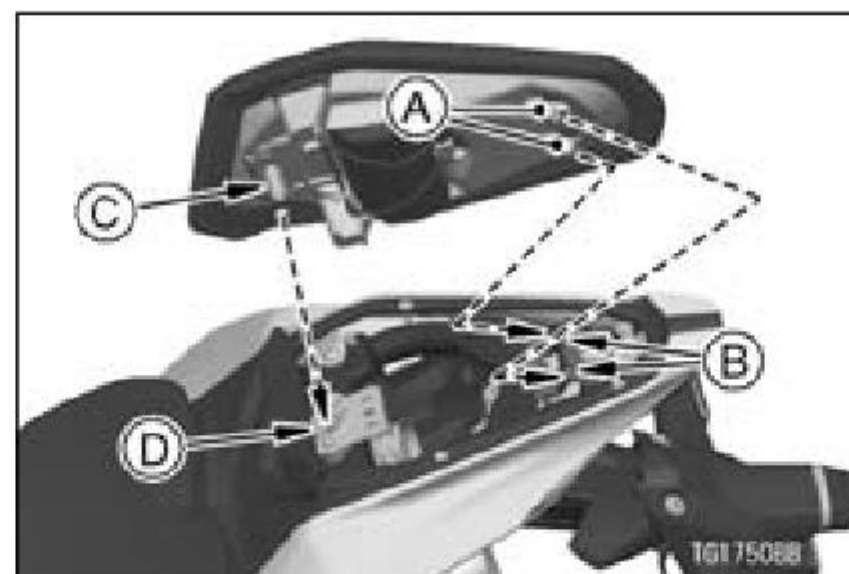

A. Hooks  
B. Slots  
C. Seat Lock Projection  
D. Latch Hole

- Pull up the front and rear ends of the passenger's seat to make sure they are securely locked.

### ***Rider's Seat Removal***

- Remove the passenger's seat (see Passenger's Seat Removal).

- Lift the rear part of the rider's seat upward while pulling the seat lock cable backward.
- Remove the rider's seat backward.

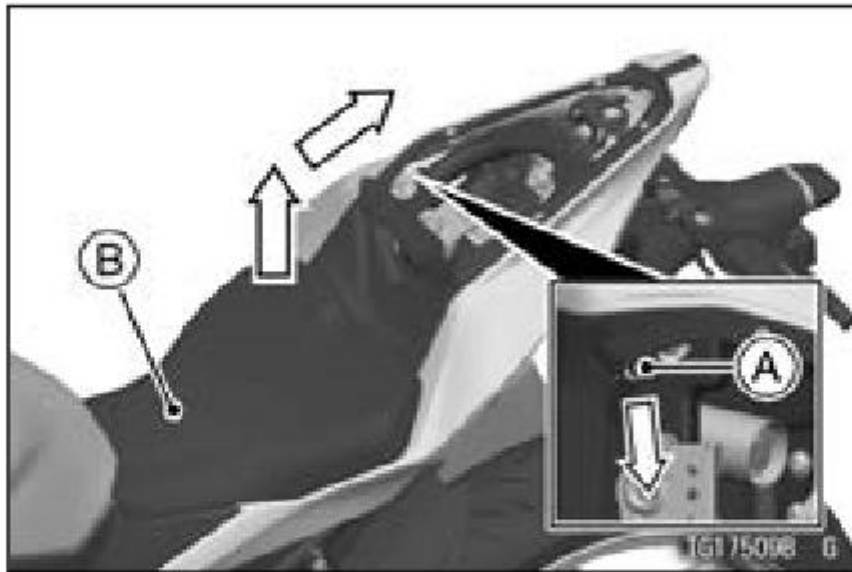

A. Seat Lock Cable  
B. Rider's Seat

***Rider's Seat Installation***

- Insert the hooks at the front of the rider's seat under the fuel tank bracket.

- Insert the seat latch at the rear part of the rider's seat into the latch hole of the frame.
- Push down the rear part of the rider's seat until the lock clicks.

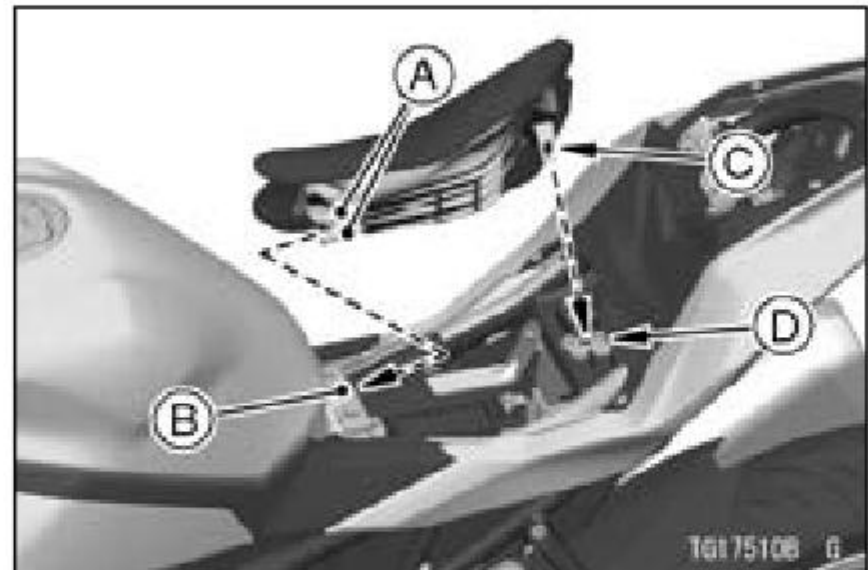

A. Hooks  
B. Fuel Tank Bracket  
C. Seat Latch  
D. Latch Hole

- Pull up the front and rear ends of the rider's seat to make sure they are securely locked.

## 106 GENERAL INFORMATION

- Install the passenger's seat (see Passenger's Seat Installation).

### Tie Hooks

When tying up light loads to the seat, use the tie hooks located in front of the rear turn signal lights and rear of the rear footpegs.

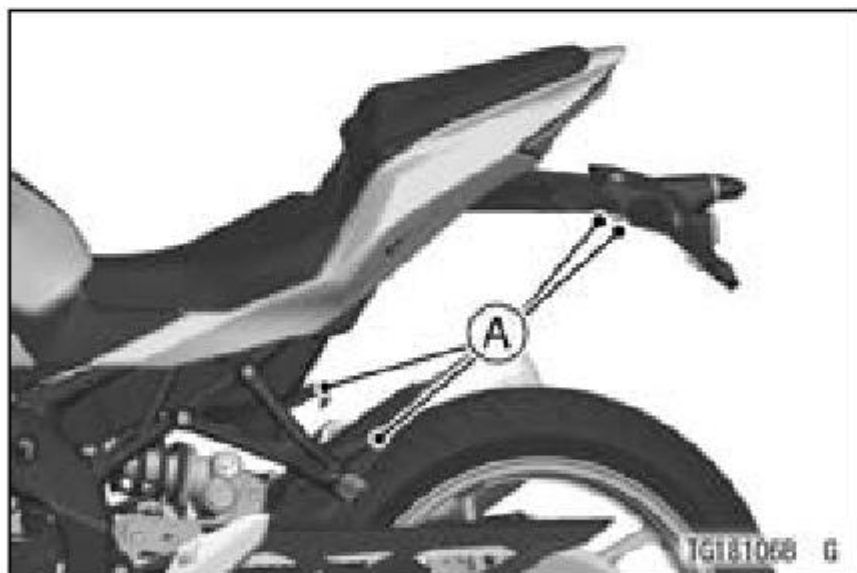

A. Tie Hooks

### Helmet Lock

The helmet lock is located to the left of the motorcycle.

#### *To unlock the helmet lock*

- Insert the ignition key into the helmet lock and turning it clockwise.

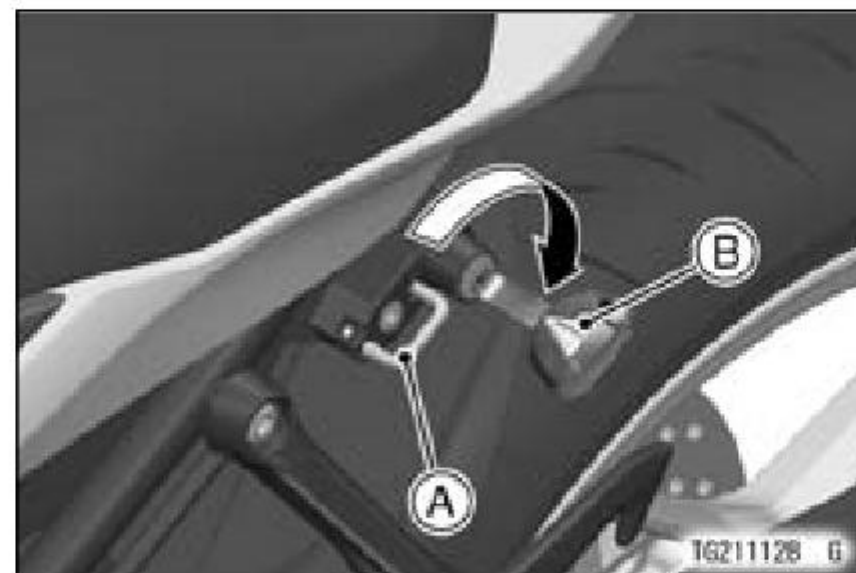

A. Helmet Lock  
B. Ignition Key

**⚠ WARNING**

Riding with a helmet attached to the lock could cause an accident by distracting the operator or interfering with normal vehicle operation. Do not ride the motorcycle with a helmet attached to the lock.

## Tool Kit

The tool kit is installed at the back side of the passenger's seat.

Keep the tool kit in the original place. Hold the tool kit with the band and the holder securely.

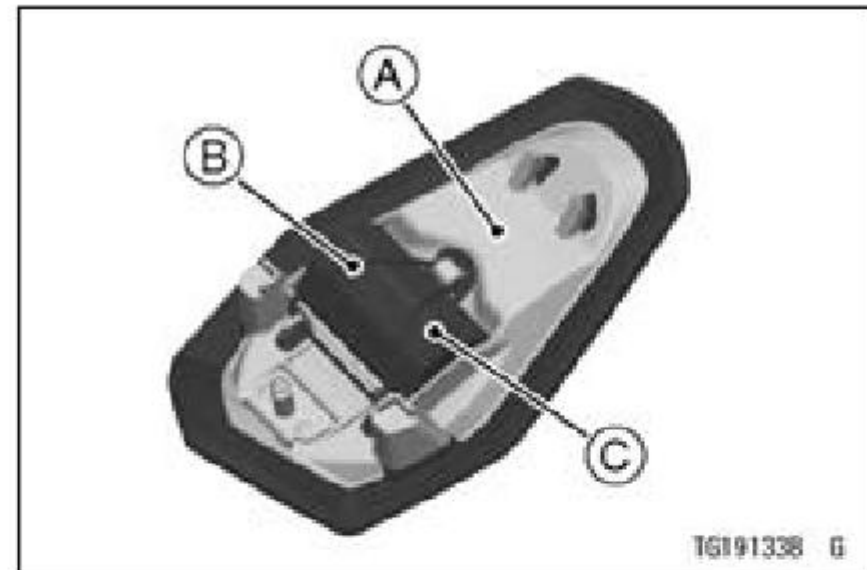

- A. Passenger's Seat
- B. Band
- C. Tool Kit

## Electrical Accessory Connectors

The electric power of the battery can be used through the electrical accessory connector.

**NOTE**

- Some models require a relay to use the electrical accessory connector.
- The electrical accessory connection to the connector should be done by an authorized Kawasaki dealer.

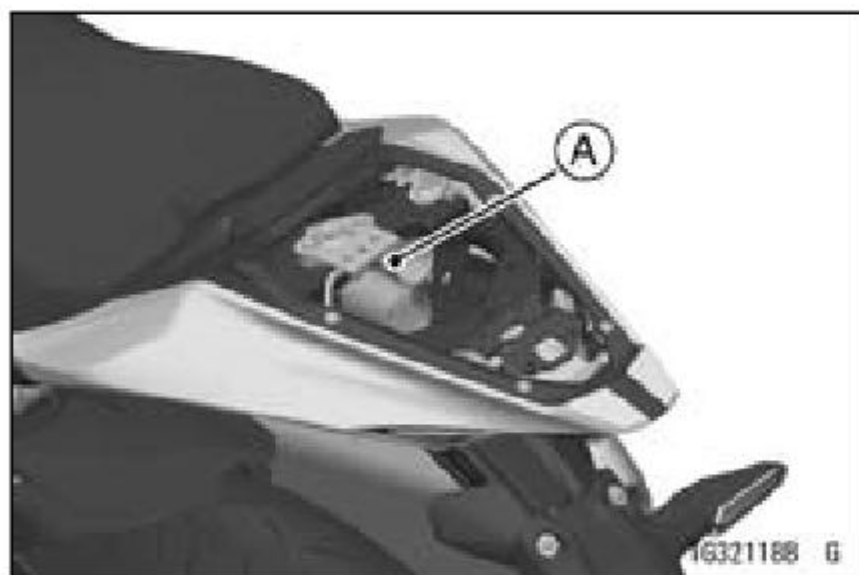

**A. For Genuine USB Socket (Under Passenger's Seat Lock Bracket)**

	Accessory Connector	Fuse Rating	Maximum Load
A	USB Socket	5 A	10.5 W

**NOTICE**

**Do not install a fuse of a higher rating than that specified. Do not connect a load that exceeds the maximum load to this accessory circuit or the battery may become discharged, even with the engine running.**

**Air Cleaner Intake**

The air cleaner intake allows air to enter the fuel system. Never allow anything to restrict the flow of air into the air cleaner. A restricted air cleaner will reduce performance and increase exhaust emissions.



**A. Air Cleaner Intake**



---

# HOW TO RIDE THE MOTORCYCLE

---

## Break-In

The first 1 000 km (600 miles) of use is the break-in period.

Follow the recommendations below to maintain the vehicle's performance and longevity.

Travelled distance	Maximum engine revolutions
0 – 200 km (0 – 150 miles)	4 000 r/min (rpm)
200 – 350 km (150 – 250 miles)	6 000 r/min (rpm)
350 – 1 000 km (250 – 600 miles)	Ride moderately

## NOTE

- *You can ride above the maximum engine revolution stated in the break-in table briefly if necessary. Brief periods above the listed engine revolutions will not affect break-in results.*
- *When travelling on public roads, obey the speed limits.*
- *Do not race the engine while the transmission is in neutral.*



**⚠ WARNING**

**New tires are slippery and may cause loss of control and injury. A break-in period of 160 km (100 miles) is necessary to establish normal tire traction. During break-in, avoid sudden and maximum braking and acceleration, and hard cornering.**

In addition to the above, at 1 000 km (600 mile) it is extremely important that the owner has the initial maintenance service performed by an authorized Kawasaki dealer.

## Starting the Engine

- Check that the engine start/stop switch is in the  position.

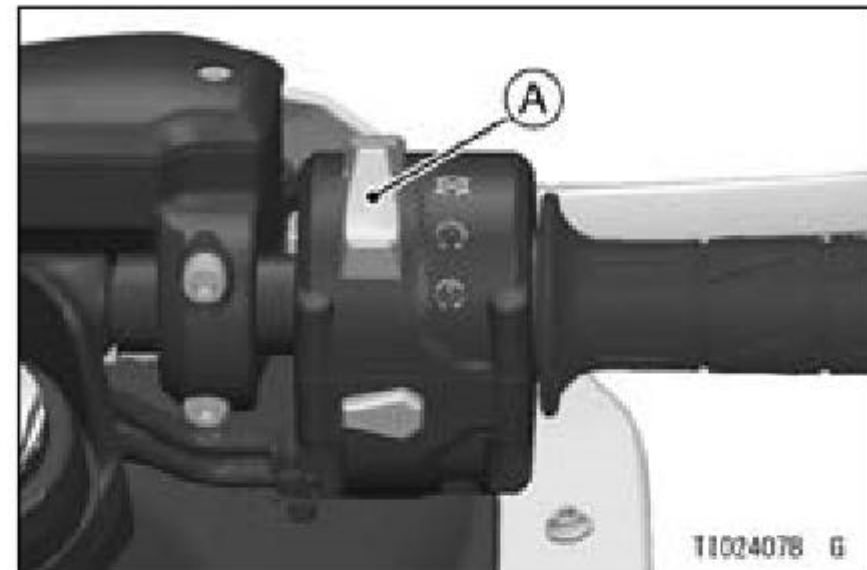

**A. Engine Start/Stop Switch**

- Turn the ignition switch on.
- Make sure the transmission is in neutral.

## 112 HOW TO RIDE THE MOTORCYCLE

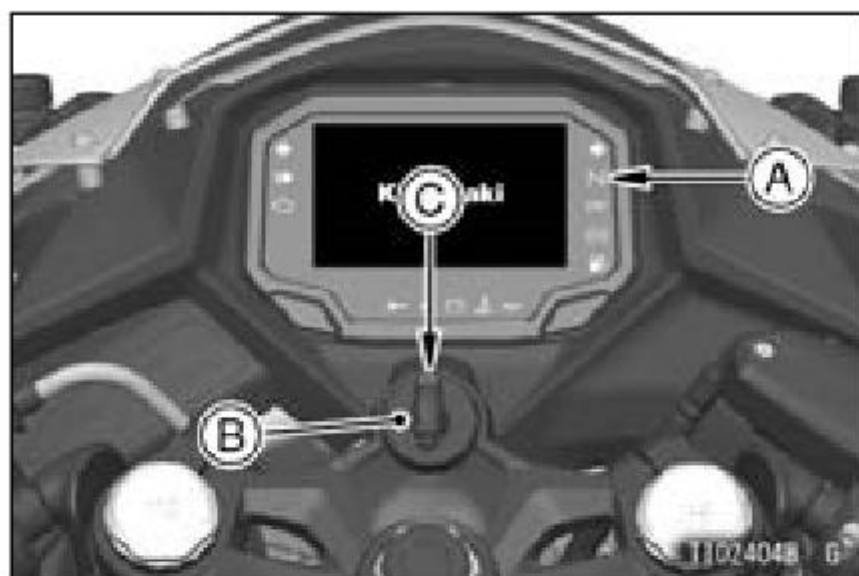

- A. Neutral Indicator (Green)
- B. Ignition Switch
- C. ON Position

### NOTE

- While the engine is cold, the fast idle system automatically raises the engine idling speed. At this time, the engine warning indicator (  ) may go on if you operate the throttle grip unnecessarily.
- The motorcycle is equipped with a vehicle-down sensor which causes

*the engine to stop automatically if the motorcycle falls down. After righting the motorcycle, first turn the ignition switch off and then turn it on before starting the engine.*

- Without holding the throttle grip, slide the engine start/stop switch to the  position to start the engine after meter initial operation is finished.

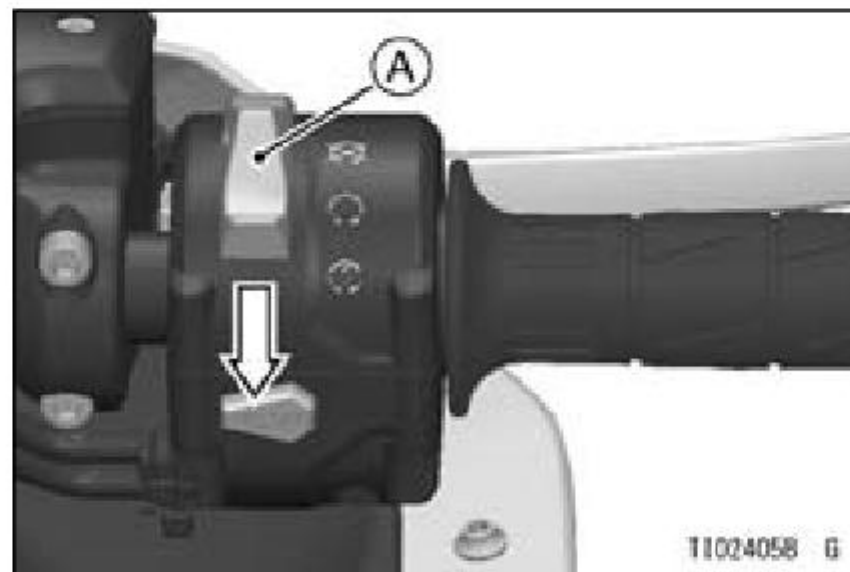

A. Engine Start/Stop Switch

**NOTICE**

Do not operate the starter continuously for more than 5 seconds, or the starter will overheat and the battery power will drop temporarily. Wait 15 seconds between each operation of the starter to let it cool and the battery power recover.

**NOTE**

- *The motorcycle is equipped with a starter lockout switch. This switch is designed so that the engine does not start if the transmission is in gear and the side stand is down. However, the engine can be started if the clutch lever is pulled and the side stand is fully up.*

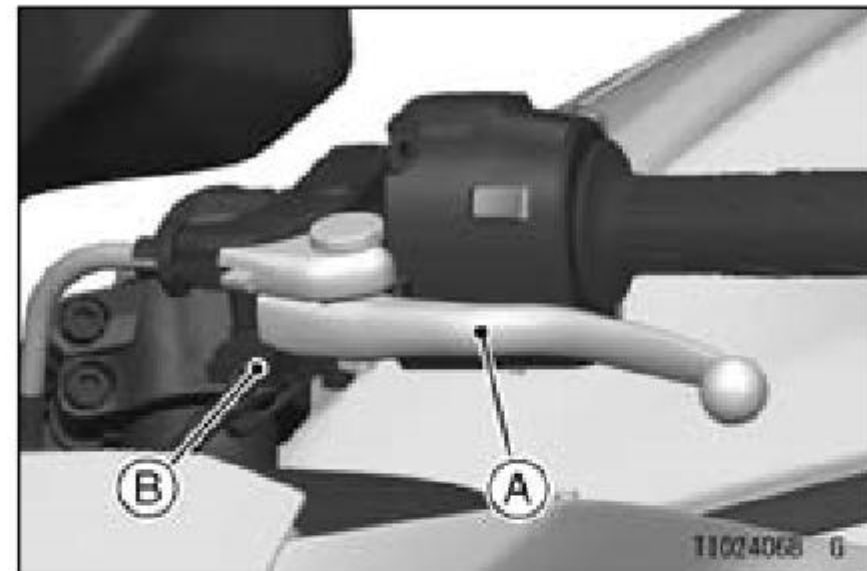

- A. Clutch Lever
- B. Starter Lockout Switch

**NOTICE**

Do not let the engine idle longer than 5 minutes, or engine overheating and damage may occur.

**Moving Off**

- Check that the side stand is up.

## 114 HOW TO RIDE THE MOTORCYCLE

- Pull in the clutch lever.
- Shift into 1st gear.
- Open the throttle a little, and start to let out the clutch lever very slowly.
- As the clutch starts to engage, open the throttle a little more, giving the engine just enough fuel to keep it from stalling.

### NOTE

- *Warm up the engine thoroughly before the riding or revving the engine.*
- *The motorcycle is equipped with a side stand switch. This switch is designed so that the engine does not start if the transmission is in gear and the side stand is down.*

## Shifting Gears

- Close the throttle while pulling in the clutch lever.

- Shift into the next higher or lower gear.

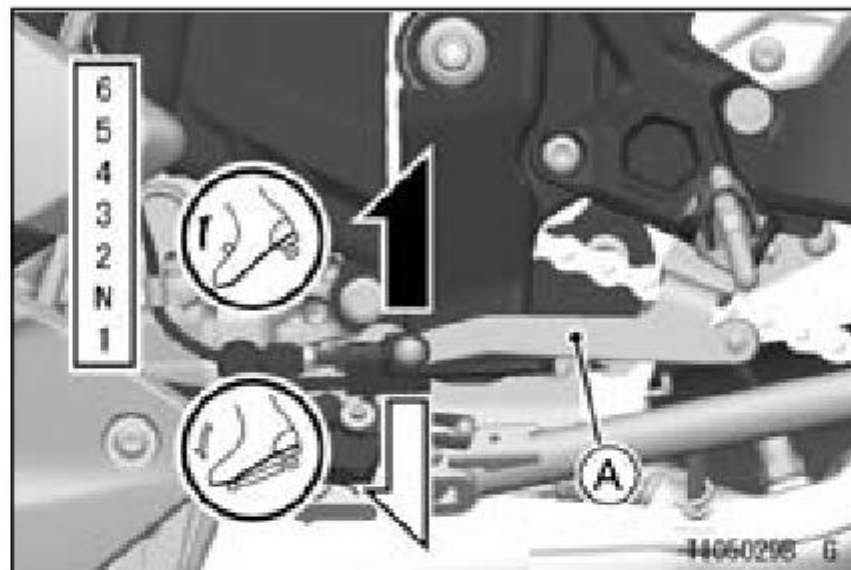

### A. Shift Pedal

- Open the throttle part way, while releasing the clutch lever.
- For smooth riding, each gear position should cover the proper rate of speed shown in the table.

**WARNING**

Downshifting to a lower gear at high speed causes engine rpm to increase excessively, potentially damaging the engine and it may also cause the rear wheel to skid and cause an accident. Downshifting should be done below the vehicle speeds for each gear shown in the table.

**Vehicle speed when shifting**

Shifting up	km/h (mph)
1st → 2nd	28 (17)
2nd → 3rd	47 (29)
3rd → 4th	60 (37)
4th → 5th	73 (45)
5th → 6th	84 (52)

Shifting down	km/h (mph)
6th → 5th	73 (45)
5th → 4th	60 (37)
4th → 3rd	47 (29)
3rd → 2nd	28 (17)
2nd → 1st	14 (9)

**NOTE**

- *The transmission is equipped with a positive neutral finder. When the motorcycle is standing still, the transmission cannot be shifted past neutral from 1st gear. To use the positive neutral finder, shift down to 1st gear, then lift up on the shift pedal while standing still. The transmission will shift only into neutral.*

## Braking

- Close the throttle completely, leaving the clutch engaged (except when shifting gears) so that the engine will help slow down the motorcycle.
- Shift down one gear at a time so that you are in 1st gear when you come to a complete stop.
- When stopping, always apply both brakes at the same time. Normally the front brake should be applied a little more than the rear. Shift down or fully disengage the clutch as necessary to keep the engine from stalling.
- Never lock the brakes, or it will cause the tires to skid. When turning a corner, it is better not to brake at all. Reduce your speed before you get into the corner.
- For emergency braking, disregard downshifting, and concentrate on

applying the brakes as hard as possible without skidding.

- Even in motorcycles equipped with ABS, braking during cornering may cause wheel slip. When turning a corner, it is better to limit braking to the light application of both brakes or not to brake at all. Reduce your speed before you get into the corner.

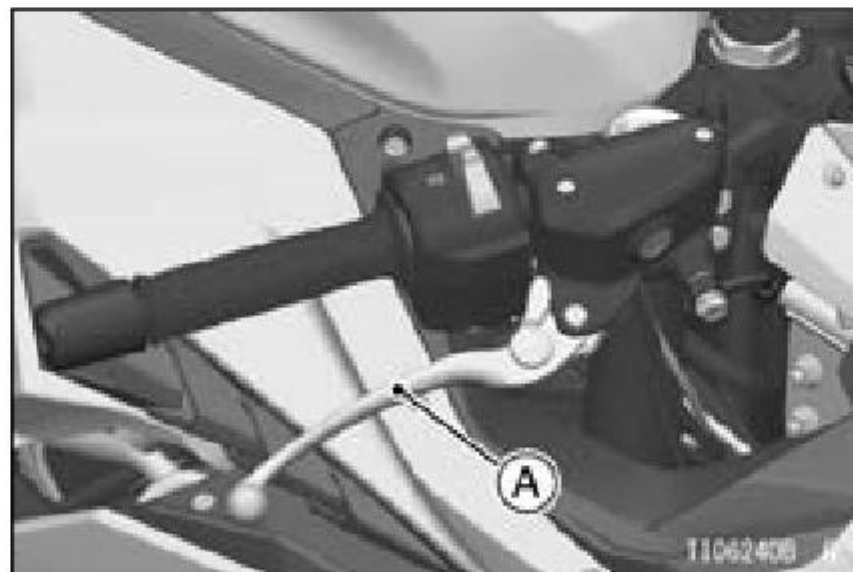

A. Front Brake Lever

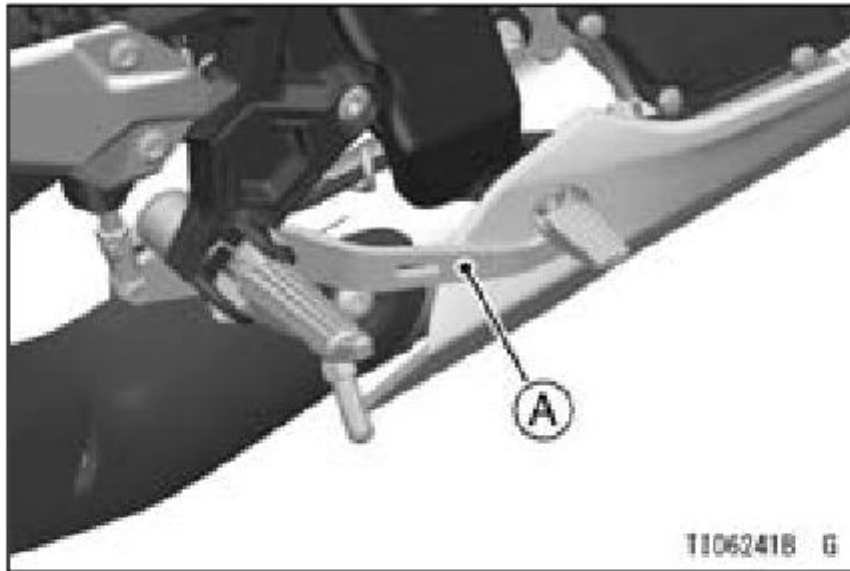

**A. Rear Brake Pedal**

## ABS

ABS (Anti-lock Brake System) is designed to help prevent the wheels from locking up when the brakes are applied hard while running straight. The ABS automatically regulates brake force. Intermittently gaining gripping force and braking force helps prevent wheel lock-up and allows stable steering control while stopping.

Brake control function is identical to that of a conventional motorcycle. The brake lever is used for the front brake and the brake pedal for the rear brake.

Although the ABS provides stability while stopping by preventing wheel lock-up, remember the following characteristics:

- To apply the brake effectively, use the front brake lever and rear brake pedal simultaneously in the same manner as conventional motorcycle brake system.
- ABS cannot compensate for adverse road conditions, misjudgment or improper application of brakes. You must take the same care as with motorcycles not equipped with ABS.
- ABS is not designed to shorten the braking distance. On loose, uneven or downhill surfaces, the stopping distance of a motorcycle with ABS

## 118 HOW TO RIDE THE MOTORCYCLE

may be longer than that of an equivalent motorcycle without ABS. Use special caution in such areas.

- ABS will help prevent wheel lock-up when braking in a straight line, but it cannot control wheel slip which may be caused by braking during cornering. When turning a corner, it is better to limit braking to the light application of both brakes or not to brake at all. Reduce your speed before you get into the corner.
- Same as conventional brake system, an excessive sudden braking may cause wheel lock up that makes it harder to control a motorcycle.
- During braking, ABS will not prevent the rear wheel lifting.

### **WARNING**

**ABS cannot protect the rider from all possible hazards and is not a substitute for safe riding practices. Be aware of how the ABS system operates and its limitations. It is the rider's responsibility to ride at appropriate speeds and manner for weather, road surface and traffic conditions.**

- The computers integrated in the ABS compare vehicle speed with wheel speed. Since non-recommended tires can affect wheel speed, they may confuse the computers, which can extend braking distance.



**WARNING**

**Use of non-recommended tires may cause malfunctioning of ABS and can lead to extended braking distance. The rider could have an accident as a result. Always use recommended standard tires for this motorcycle.**

**NOTE**

- *When the ABS is functioning, you may feel a pulsing in the brake lever or pedal. This is normal. You need not suspend applying brakes.*
- *ABS does not function if the battery is discharged. When riding with an insufficiently charged battery, ABS*

*may not function. Keep the battery in good condition according to the Battery Maintenance section in the MAINTENANCE AND ADJUSTMENT chapter.*

- *ABS does not function at below speed.*

Approximately 10 km/h (6.2 mph) or below

## Stopping the Engine

- Close the throttle completely.
- Shift the transmission into neutral.
- Turn the ignition switch off.
- Support the motorcycle on a firm, level surface with the side stand.
- Lock the steering.

## Stopping the Motorcycle in an Emergency

Your Kawasaki Motorcycle has been designed and manufactured to provide you optimum safety and convenience. However, in order to fully benefit from Kawasaki's safety engineering and craftsmanship, it is essential that you, the owner and operator, properly maintain your motorcycle and become thoroughly familiar with its operation. Improper maintenance can create a dangerous situation known as throttle failure. Two of the most common causes of throttle failure are:

1. An improperly serviced or clogged air cleaner may allow dirt and dust

to enter the throttle body and stick the throttle open.

2. During removal of the air cleaner, dirt is allowed to enter and jam the fuel injection system.

In an emergency situation such as throttle failure, your vehicle may be stopped by applying the brakes and disengaging the clutch. Once this stopping procedure is initiated, the engine stop switch may be used to stop the engine. If the engine stop switch is used, turn off the ignition switch after stopping the motorcycle.

## Parking

### **WARNING**

Operating or parking the vehicle near flammable materials can cause a fire, and can result in property damage or severe personal injury.

Do not idle or park your vehicle in an area where tall or dry vegetation, or other flammable materials could come into contact with the muffler or exhaust pipe.

### **WARNING**

The engine and exhaust system get extremely hot during normal operation and can cause serious burns.

Never touch a hot engine, exhaust pipe, or muffler during operation or after stopping the engine.

- Shift the transmission into neutral and turn the ignition switch off.
- Support the motorcycle on a firm, level surface with the side stand.

### **NOTICE**

Do not park on a soft or steeply inclined surface, or the motorcycle may fall over.

- If parking inside a garage or other structure, be sure it is well ventilated

## 122 HOW TO RIDE THE MOTORCYCLE

and the motorcycle is not close to any source of flame or sparks; this includes any appliance with a pilot light.

### **WARNING**

**Gasoline is extremely flammable and can be explosive under certain conditions, creating the potential for serious burns. Turn the ignition switch off. Do not smoke. Make sure the area is well ventilated and free from any source of flame or sparks; this includes any appliance with a pilot light.**

- Lock the steering to help prevent theft.

## Integrated Riding Modes



This motorcycle can change its performance characteristics with the press of a button only. This system has three different preset modes and they integrally control the engine.

### **SPORT:**

Power mode	F
KTRC	1

**ROAD:**

Power mode	F
KTRC	2

**RAIN:**

Power mode	L
KTRC	3

**How to Switch Integrated Riding Modes**

- Push and hold the upper or lower button to switch the mode.

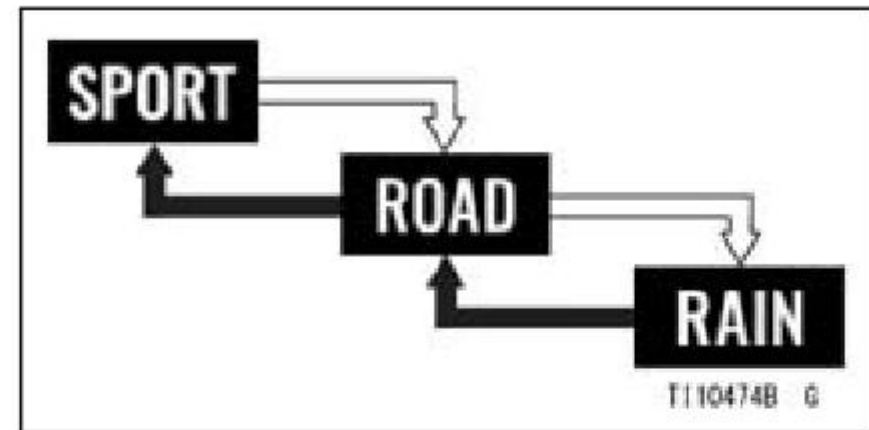

- ➡ : Flow when pushing and holding the upper button
- ↳ : Flow when pushing and holding the lower button

- The modes cannot be switched on following situation:
  - When the throttle grip is open.

**RIDER Mode**

In addition to three different riding modes, the RIDER mode that can be set to your preference. Two system parameters are adjustable manually: Power modes and KTRC.

## 124 HOW TO RIDE THE MOTORCYCLE

### *How to Switch to RIDER Mode*

- Push and hold the lower button when the riding mode is RAIN.

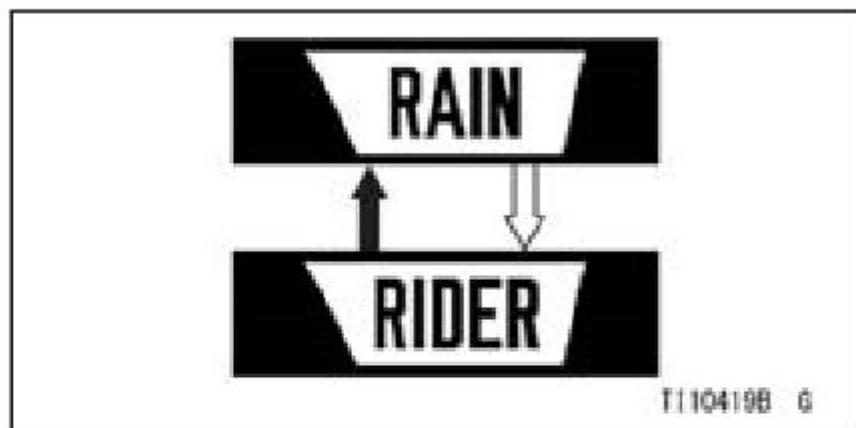

→ : Flow when pushing and holding the upper button

⇨ : Flow when pushing and holding the lower button

- The modes cannot be switched on following situation:
  - When the throttle grip is open.

### **NOTE**

- When switching to the RIDER mode, KTRC and power mode parameters appear as shown. These parameters display over a part of the multifunction display and the coolant temperature meter.

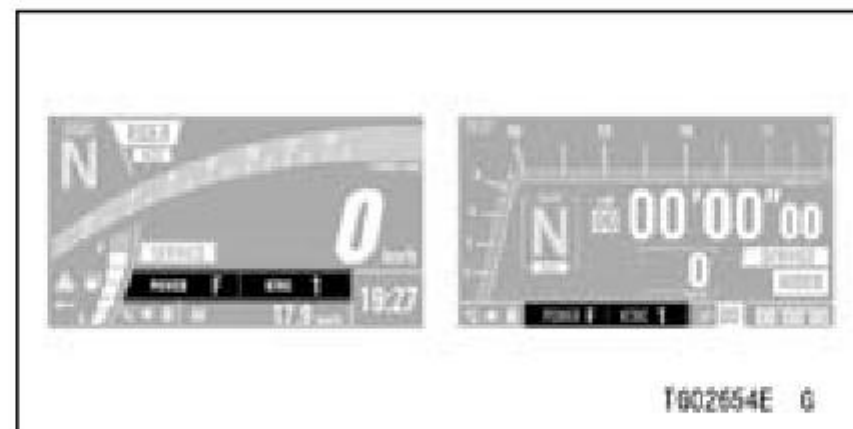

- Push and hold the SELECT button to disappear the parameters.
- To display the parameters again, push the SELECT button.

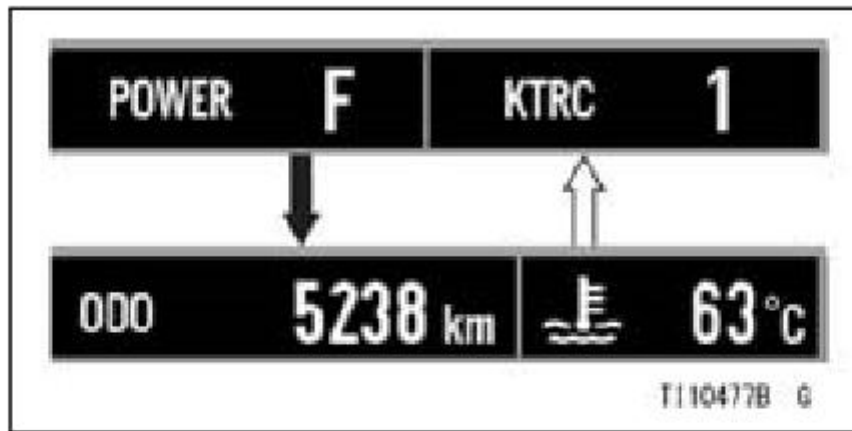

- ➡ : Flow when pushing and holding the SELECT button
- ↳ : Flow when pushing the SELECT button

### RIDER Mode Parameters

By combining the power mode and KTRC, some combination settings are available to suit your preference.

The combination of each mode should be decided according to riding skill and road conditions. Set the

combination by referring to the following table.

### Examples of mode combinations

	Sport	City	Wet / Slippery Road
Power Mode	F	L	L
KTRC Mode	OFF	1	2

The table shows combinations of Power Mode and KTRC Mode. The Power Mode row shows 'F' for Sport, 'L' for City, and 'L' for Wet / Slippery Road. The KTRC Mode row shows 'OFF' for Sport, '1' for City, and '2' for Wet / Slippery Road. The text 'T110232B G' is visible at the bottom right of the table.

**How to Change Parameters**

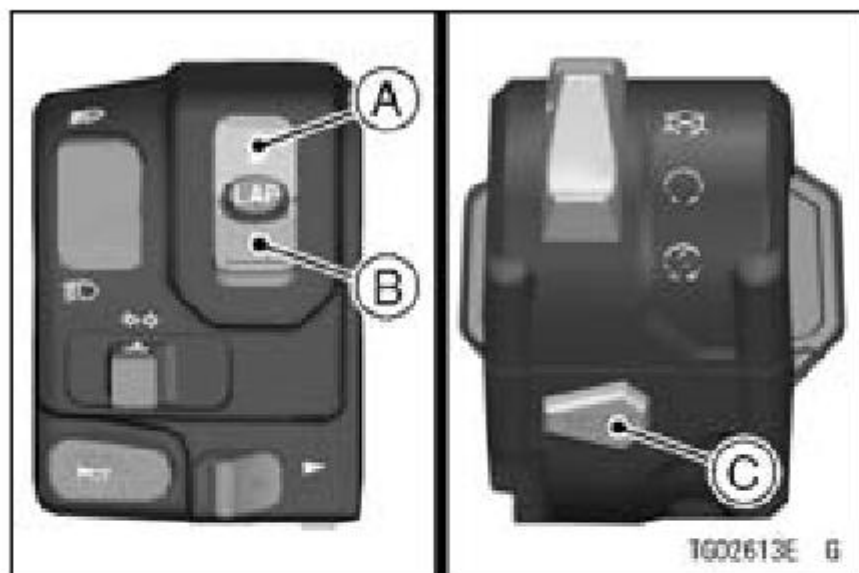

- A. Choose the mode
- B. Choose the mode
- C. Move selected item

- Display the RIDER mode parameters.
- Push the SELECT button to shift to the parameter to be changed.
- The parameter cannot be shifted on following situations:

○ When the throttle grip is open.

○ When the vehicle speed exceeds 5 km/h (3 mph).

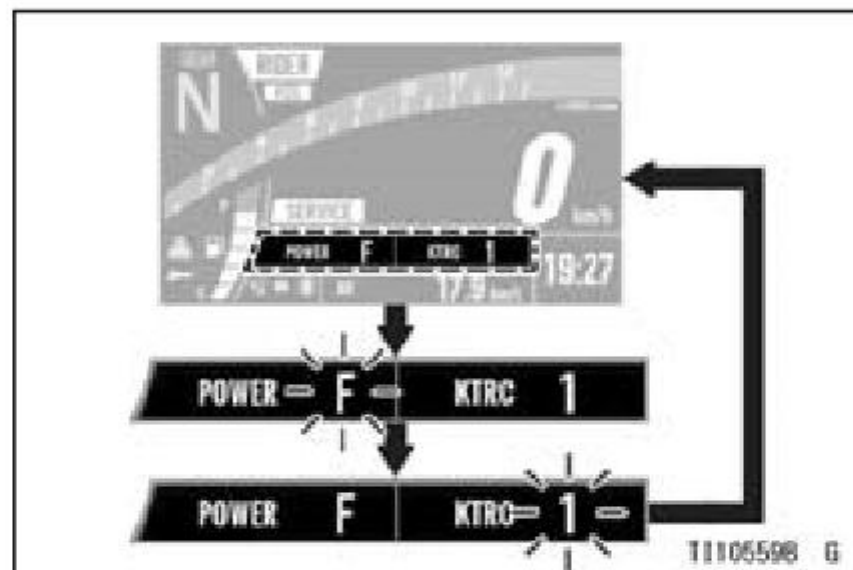

➔ : Flow when pushing SELECT button

- Blink the mode of "POWER" using the SELECT button.
- Choose the mode using the upper or lower button.

Mode	Characteristics
F	Full power
L	Low power



- Push the SELECT button.
- Choose the KTRC mode in the same way.

Mode	System intervention level
OFF	No intervention
1	Low
2	Middle
3	High

**NOTE**

- *Operate the throttle carefully while KTRC is off because rear wheelspin cannot be controlled.*
- *When KTRC is off, KTRC OFF indicator appears on the display screen.*

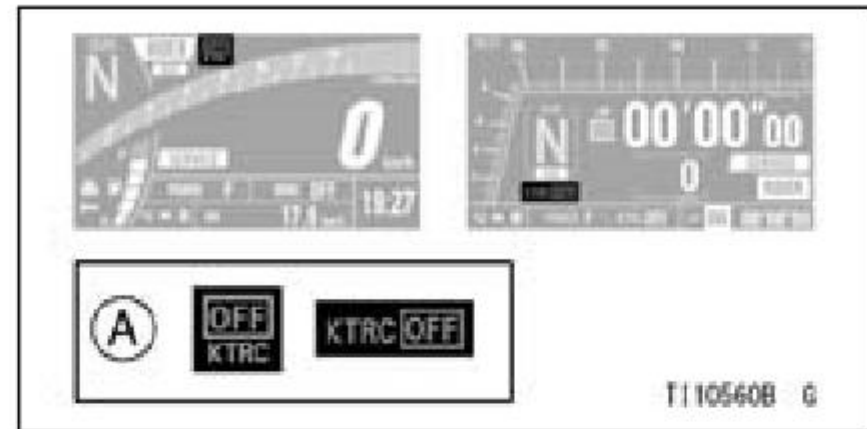

A. KTRC OFF Indicator

**KTRC**

KTRC (Kawasaki TRaction Control) is an intelligent system that calculates the slip level of the rear wheel (wheelspin) during acceleration and controls the optimum slip ratio to suit the riding conditions. KTRC can contribute to a stable ride not only for sports riding but also when riding on a rough or slippery road surface.

## 128 HOW TO RIDE THE MOTORCYCLE

KTRC is designed for use on public roads. KTRC cannot respond to every condition. Acceleration may be delayed under certain conditions.

### **WARNING**

**KTRC cannot protect the rider from all possible hazards and is not a substitute for safe riding practices. Be aware of how the KTRC system operates and its limitations. It is the rider's responsibility to ride at appropriate speeds and manner for weather, road surface and traffic conditions.**

If a wheelie occurs due to excessive acceleration, KTRC will control the engine output to make the front wheel contact the road surface. In this case,

slightly release the throttle grip so that the front wheel stays in contact with the road surface.

### **WARNING**

**Use of non-recommended tires could cause a malfunction or improper operation of KTRC. Always use recommended standard tires for this motorcycle.**

### *KTRC Indicator*



KTRC indicator blinks while the system intervenes.

### ***KTRC Modes***

KTRC determines the traction control characteristics with three mode selections. KTRC can also be set to OFF.

#### **Mode 1:**

KTRC has the least intervention among the three modes. This mode gives maximum acceleration for sport riding.

#### **Mode 2:**

KTRC intervention is moderate, about half way between the mode 1 and mode 3.

#### **Mode 3:**

KTRC intervenes early to help prevent the rear wheel from spinning whenever possible. This mode is used in low grip situations.

#### **OFF:**

KTRC does not intervene. Operate the throttle carefully since the rear wheel spin cannot be controlled.

### **Power Mode**

The power mode determines the engine power output characteristics and has two settings.

#### **Mode F (Full Power):**

The highest engine power output is achieved. The rider can feel the full throttle response of the engine.

#### **Mode L (Low Power):**

The throttle response is milder than F mode.

## KQS

KQS (Kawasaki Quick Shift) enables shifting gears up and down without operating the clutch lever. KQS is not designed for shifting automatically. Therefore, you must use the same shift pedal operation as with motorcycles not equipped with KQS.

### NOTE

- *KQS system does not work while the clutch lever is being pulled.*
- *KQS system does not work properly below approximately 2 500 r/min (rpm).*
- *Following any up or down shift, the shift pedal must be fully released before another shift with KQS can be made.*

### **Upshifting**

During acceleration, KQS system allows you to upshift without operating the clutch and letting off the throttle.

### NOTE

- *The upshifting function of KQS system does not work when the throttle is closed.*

### **Downshifting**

During deceleration, KQS system allows you to downshift without operation the clutch.

### NOTE

- *The downshifting function of KQS system works only when the throttle is closed.*
- *The downshifting function of KQS system does not work when the engine speed is high (near the red zone on the tachometer).*

**KQS Setting**

- Close the throttle grip completely.
- Push the SELECT and lower buttons simultaneously and hold them in until KQS mode indicator appears.

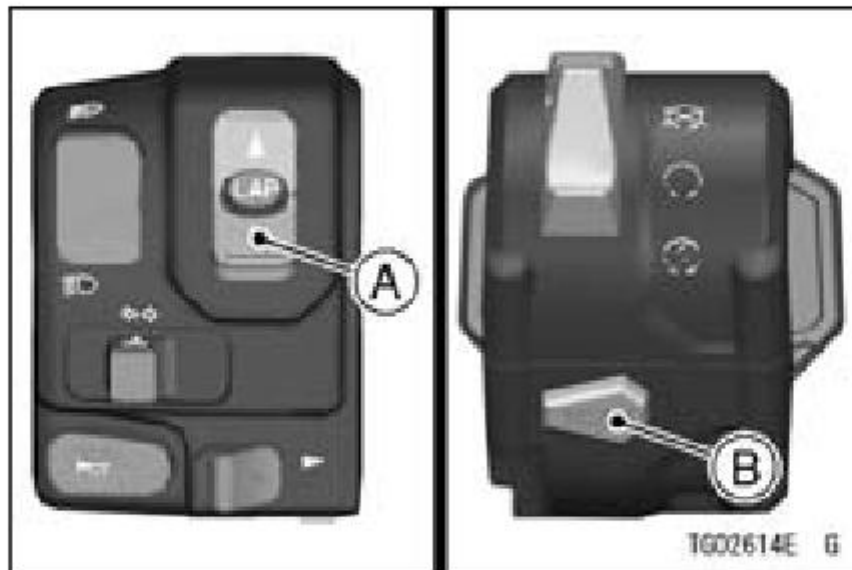

A. Lower Button  
B. SELECT Button

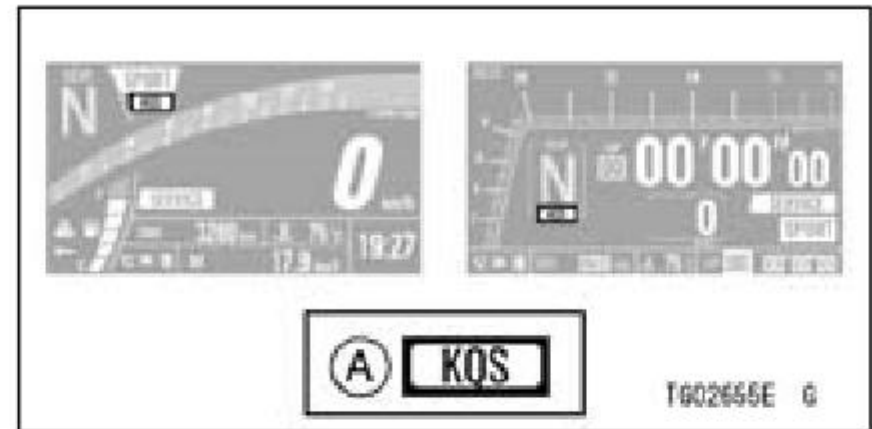

A. KQS Mode Indicator

- To turn off, push the SELECT and lower buttons simultaneously and hold them in until KQS mode indicator disappears.

**NOTE**

- *When changing the mode, stop the motorcycle.*

## MAINTENANCE AND ADJUSTMENT

The maintenance and adjustments outlined in this chapter must be carried out in accordance with the Daily Checks and Periodic Maintenance to keep the motorcycle in good running condition and to reduce air pollution. **The initial maintenance is vitally important and must not be neglected.**

### **WARNING**

**Failure to perform these checks or to correct a problem before operation may result in serious damage or an accident. Always perform daily checks before operation.**

Although items other than daily maintenance are described, this maintenance and repair work should be done by qualified technicians. Kawasaki does not recommend doing this work without knowledge and proper tools. Please note that Kawasaki cannot assume any responsibility for damage resulting from incorrect or improper adjustment made by the owner.

 **DANGER**

**Exhaust gas contains carbon monoxide, a colorless, odorless poisonous gas. Inhaling carbon monoxide can cause serious brain injury or death. DO NOT run the engine in enclosed areas. Operate only in a well-ventilated area.**

**NOTE**

- *If a torque wrench is not available, the maintenance items which require a specific torque value should be serviced by an authorized Kawasaki dealer.*

## Daily Checks

Check the following items each day before you ride. The time required is minimal, and habitual performance of these checks will help ensure you a safe, reliable ride.

If any irregularities are found during these checks, contact an authorized Kawasaki dealer. Temporary measures methods are described on each page.

Operation	See Page
<b>Fuel</b> Adequate supply in tank, no leaks	—
<b>Engine Oil</b> Oil level between level lines	142
<b>Tires</b> Air pressure (when cold), install the air valve cap Tire wear	166 167
<b>Drive Chain</b> Slack: every 1 000 km (600 mile) Lubricate: every 600 km (400 mile)	152 151







Operation	See Page
<p><b>Bolt, nuts and fasteners</b></p> <p>Check for loose and/or missing bolts, nuts and fasteners</p>	<p>—</p>
<p><b>Steering</b></p> <p>Action smooth but not loose from lock to lock</p> <p>No binding of control cables</p>	<p>—</p> <p>—</p>
<p><b>Brakes</b></p> <p>Brake pad wear</p> <p>Brake fluid level</p> <p>No brake fluid leakage</p>	<p>157</p> <p>156</p> <p>—</p>
<p><b>Throttle</b></p> <p>Throttle grip operates smoothly</p>	<p>149</p>
<p><b>Clutch</b></p> <p>Clutch lever play</p> <p>Clutch lever operates smoothly</p>	<p>150</p> <p>—</p>

## 136 MAINTENANCE AND ADJUSTMENT

Operation	See Page
<b>Coolant</b> No coolant leakage Coolant level between level lines (when engine is cold)	— 145
<b>Electrical equipment</b> All lights (head, city, brake/tail, turn signal, license plate, warning/indicator), meter and horn work	—
<b>Engine stop switch</b> Stops engine	—
<b>Side stand</b> Return to its fully up position by spring tension Return spring not weak or not damaged	— —
<b>Rear view mirrors</b> Rear view sight	—

## Periodic Maintenance

- \*A: Service at number of years shown or indicated odometer reading intervals, whichever comes first.
- \*B: For higher odometer readings, repeat at the frequency interval established here.
- \*C: Service more frequently when operating in severe conditions: dusty, wet, muddy, high speed, or frequent starting/stopping.

-  ○: Emission Related Item
-  Q: Dealer Inspection
-  ↻: Dealer Change or Replace
-  ⚙️: Dealer Lubrication

## 138 MAINTENANCE AND ADJUSTMENT

Items	Year (*A)	Odometer Reading (*B) × 1 000 km (× 1 000 mile)					See Page
		1 (0.6)	12 (7.6)	24 (15.2)	36 (22.8)	48 (30.4)	
○ Air cleaner element (*C)				↻		↻	148
○ Idle speed		Q	Q	Q	Q	Q	149
○ Throttle control system (smooth return)	Q:1	Q	Q	Q	Q	Q	149
○ Engine vacuum synchronization			Q	Q	Q	Q	—
Fuel system	Q:1	Q	Q	Q	Q	Q	—
Fuel filter				↻		↻	—
Fuel hose	↻:5						—
○ Evaporative emission control system				Q		Q	—
Cooling system	Q:1	Q	Q	Q	Q	Q	—
Coolant, water hose and O-ring	↻:3				↻		—

Items	Year (*A)	Odometer Reading (*B) × 1 000 km (× 1 000 mile)					See Page
		1 (0.6)	12 (7.6)	24 (15.2)	36 (22.8)	48 (30.4)	
○ Valve clearance				Q		Q	—
○ Air suction system			Q	Q	Q	Q	—
Clutch operation (play, engagement, disengagement)	Q:1	Q	Q	Q	Q	Q	150
Engine oil (*C) and oil filter	↻:1	↻	↻	↻	↻	↻	143
Wheel bearing damage	Q:1		Q	Q	Q	Q	—
Drive chain wear (*C)			Q	Q	Q	Q	—
Drive chain guide wear			Q	Q	Q	Q	—
Brake system	Q:1	Q	Q	Q	Q	Q	—
Brake operation (effectiveness, play, no drag)	Q:1	Q	Q	Q	Q	Q	—
Brake fluid (front and rear)	↻:2			↻		↻	—

## 140 MAINTENANCE AND ADJUSTMENT

Items	Year (*A)	Odometer Reading (*B) × 1 000 km (× 1 000 mile)					See Page
		1 (0.6)	12 (7.6)	24 (15.2)	36 (22.8)	48 (30.4)	
Brake hose	:4						—
Rubber parts of brake master cylinder and caliper	:4						—
Suspension system	Q:1		Q	Q	Q	Q	—
Lubrication of rear suspension							—
Steering play	Q:1	Q	Q	Q	Q	Q	—
Steering stem bearing	:2						—
Electrical system	Q:1		Q	Q	Q	Q	—
○ Spark plug							—
Chassis parts	:1						—
Condition of bolts, nuts and fasteners		Q	Q	Q	Q	Q	—

**NOTE**

- *All owner daily maintenance items should also be checked at every scheduled dealer service.*



## Engine Oil

### *Oil Level Inspection*

- If the engine is cold, start the engine and run it for several minutes at idle speed.
- Stop the engine, then wait several minutes until the oil settles.

### **NOTICE**

**Racing the engine before the oil reaches every part can cause engine seizure.**

- Check the engine oil level through the oil level inspection window. With the motorcycle held level, the oil level should come up between the upper and lower level lines next to the oil level inspection window.

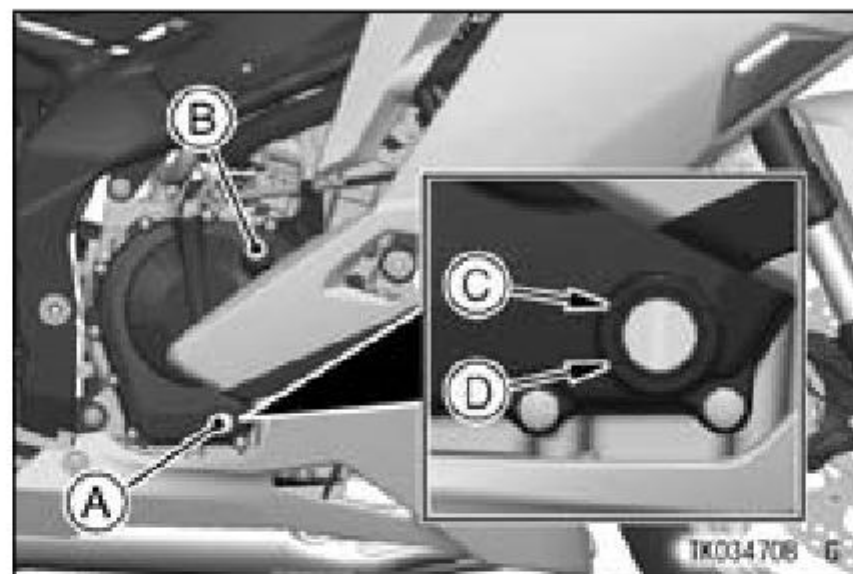

- A. Oil Level Inspection Window
- B. Oil Filler Cap
- C. Upper Level Line
- D. Lower Level Line

- If the oil level is too high, remove the excess oil through the oil filler opening using a syringe or some other suitable device.
- If the oil level is too low, add oil to reach the correct level. Use the same type and brand of oil that is already in the engine.



**Oil and/or Oil Filter Change**

- The oil change and oil filter replacement should be done by an authorized Kawasaki dealer.

**⚠ WARNING**

Engine oil is a toxic substance. Dispose of used oil properly. Contact your local authorities for approved disposal methods or possible recycling.

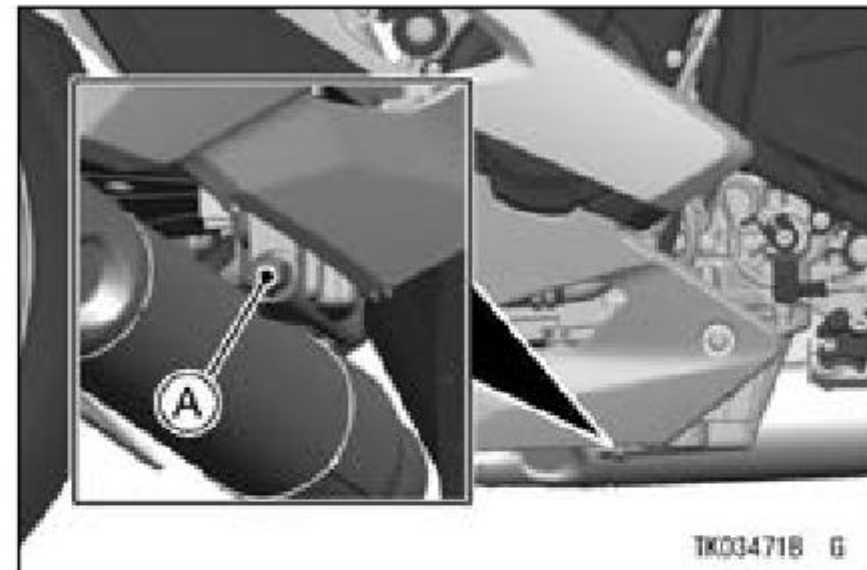

A. Engine Oil Drain Bolt

**Tightening Torque**

Engine Oil Drain Bolt:

30 N·m (3.1 kgf·m, 22 ft·lb)

## 144 MAINTENANCE AND ADJUSTMENT

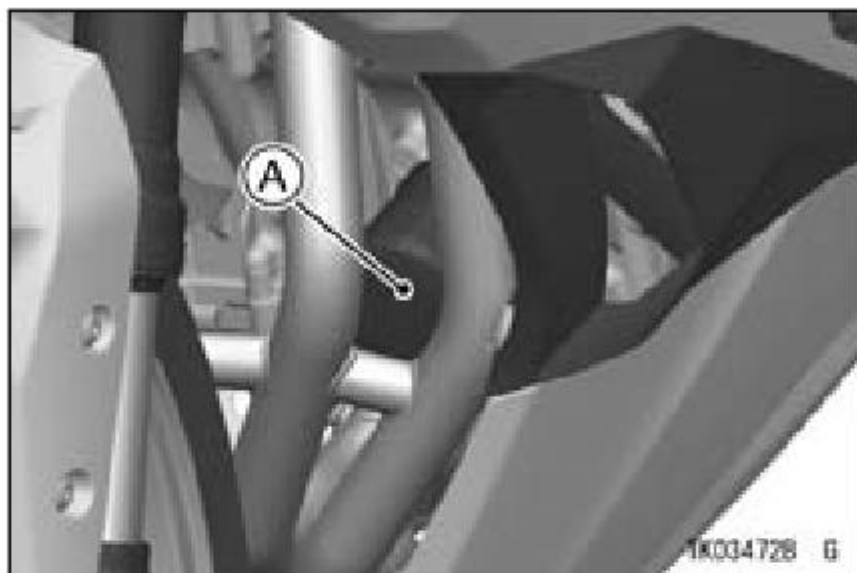

### A. Oil Filter

#### Tightening Torque

Oil Filter:

17.5 N·m (1.78 kgf·m, 12.9 ft·lb)

### Recommended Engine Oil

Type:

Kawasaki Performance 4-Stroke  
Motorcycle Oil\*

Kawasaki Performance 4-Stroke  
Semi-Synthetic Oil\*

Kawasaki Performance 4-Stroke Full  
Synthetic Oil\*

or other 4-stroke oils with API SG, SH,  
SJ, SL or SM with JASO MA, MA1 or  
MA2 rating

Viscosity:

SAE 10W-40

\*Kawasaki Performance Oils and Lubricants have been specifically engineered for your vehicle. Consistent use of these products meets or exceeds warranty and service requirements and can help to extend the life of your Kawasaki.

**NOTE**

○ Do not add any chemical additive to the oil. Oils fulfilling the above requirements are fully formulated and provide adequate lubrication for both the engine and the clutch.

**Engine Oil Capacity**

Capacity: 2.3 L (2.4 US qt)  
 [when filter is not removed]  
 2.6 L (2.7 US qt)  
 [when filter is removed]

Although 10W-40 engine oil is the recommended oil for most conditions, the oil viscosity may need to be changed to accommodate atmospheric conditions in your riding area.

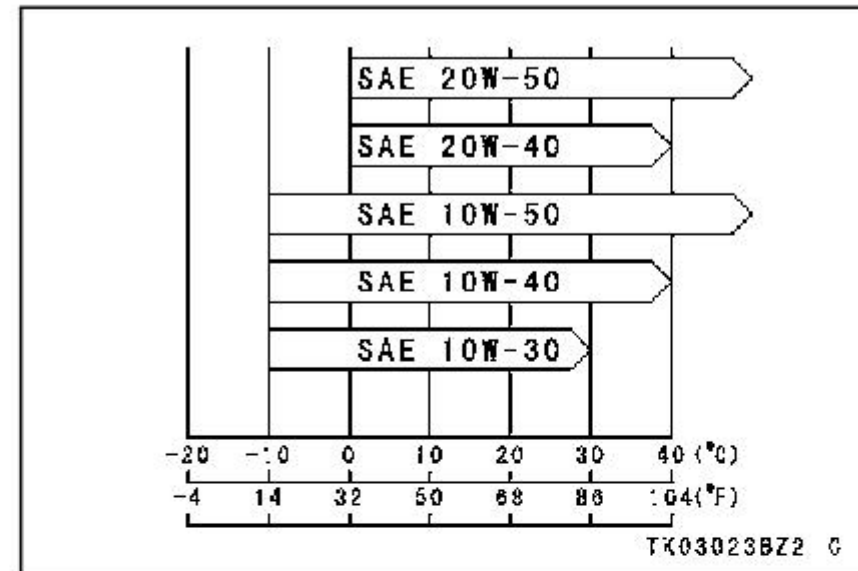

**Coolant**

**Coolant Level Inspection**

- Position the motorcycle so that it is perpendicular to the ground.
- Check the coolant level through the coolant level gauge on the reserve tank located the back of right lower fairing. The coolant level should be between the F (Full) and L (Low) level lines.

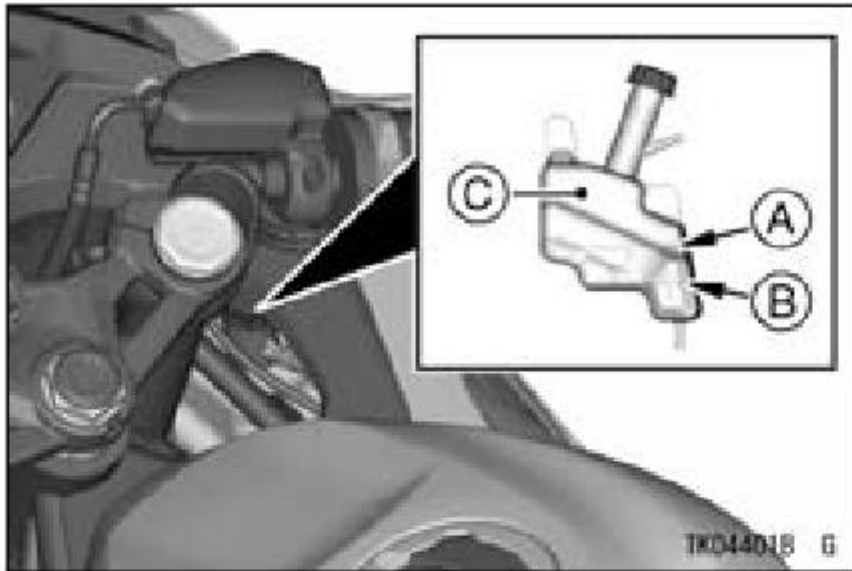

- A. F (Full) Level Line
- B. L (Low) Level Line
- C. Reserve Tank

### NOTE

- Check the level when the engine is cold (room or atmospheric temperature).
- If the amount of coolant is insufficient, add coolant into the reserve tank.

### Coolant Filling

- Remove the reserve tank cap from the reserve tank and add coolant through the filler opening between the F (Full) and L (Low) level lines.

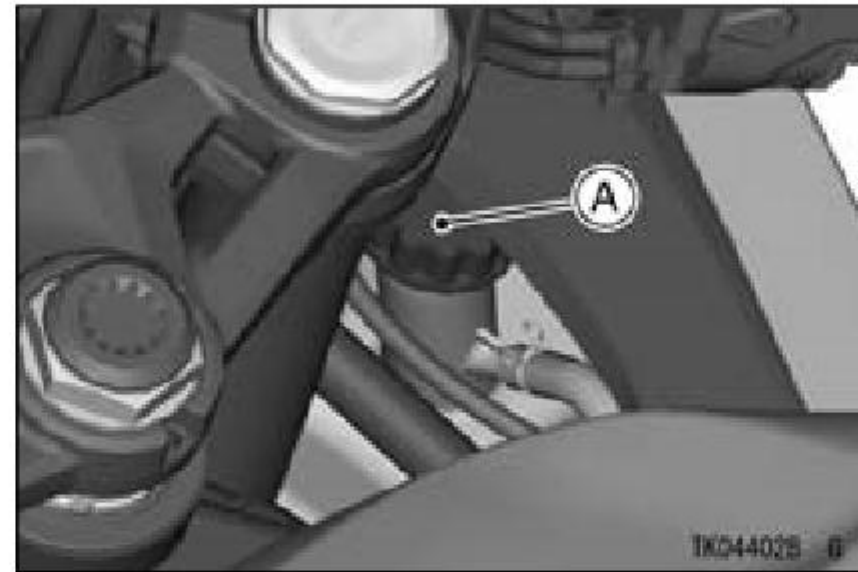

- A. Reserve Tank Cap

### NOTE

- In an emergency you can add water alone to the coolant reserve tank, however it must be returned to the

*correct mixture ratio by the addition of antifreeze concentrate as soon as possible.*

### **NOTICE**

If coolant must be added often, or the reserve tank completely runs dry, there is probably leakage in the system. Have the cooling system inspected by your authorized Kawasaki dealer.

- Install the reserve tank cap.

### **Coolant Change**

Have the coolant changed by an authorized Kawasaki dealer.

### **Coolant Requirement**

#### **WARNING**

Coolant containing corrosion inhibitors for aluminum engines and radiators include harmful chemicals for human body. Drinking coolant can result in serious injury or death. Use coolant in accordance with the instructions of the manufacturer.

Use a permanent type of antifreeze (soft water and ethylene glycol plus corrosion and rust inhibitor chemicals for aluminum engines and radiators) in the cooling system. On the mixture ratio of coolant, choose the suitable one referring to the relation between freezing point and strength directed on the container.

**NOTICE**

If hard water is used in the system, it causes scale accumulation in the water passages, and considerably reduces the efficiency of the cooling system.

**NOTE**

- A permanent type of antifreeze is installed in the cooling system when shipped. It is mixed at 50% and has the freezing point of  $-35^{\circ}\text{C}$  ( $-31^{\circ}\text{F}$ ).

**Air Cleaner**

This motorcycle's air cleaner element consists of a wet paper filter. Replacement of the air cleaner element should be done by an authorized Kawasaki dealer.

**Oil Draining**

- Inspect the transparent drain hose located to the left of the engine to see if any oil has run down.

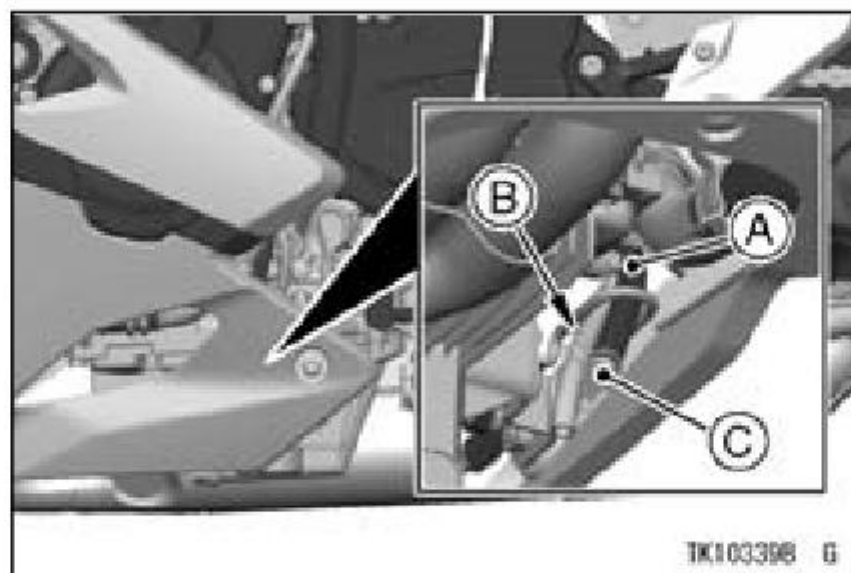

A. Transparent Drain Hose

B. Clamp

C. Plug

- If there is any oil in the transparent drain hose, remove the clamp and plug from the lower end of the drain hose, and drain the oil.

 **WARNING**

Oil on tires will make them slippery and can cause an accident and injury. Be sure to install the plug in the drain hose after draining.

## Throttle Control System

### *Throttle Operation Inspection*

- Check that the throttle grip moves smoothly from full open to close.

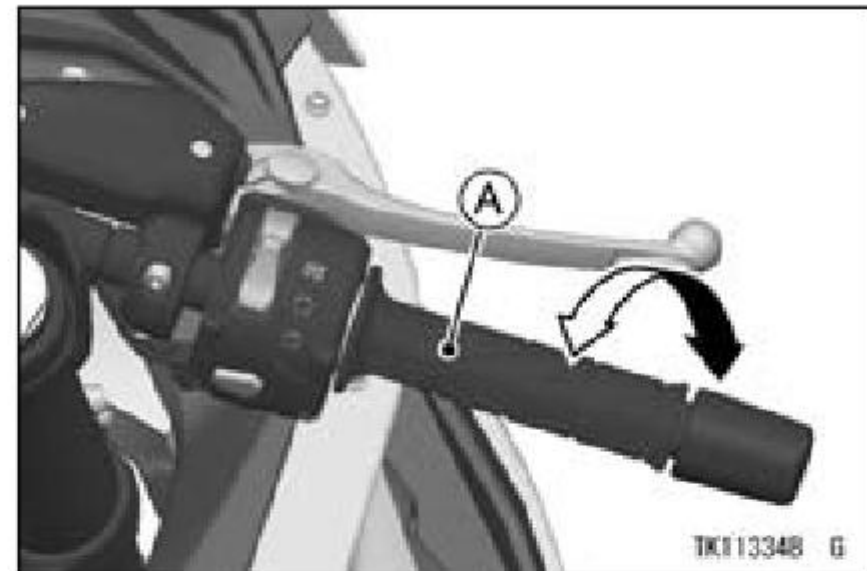

### A. Throttle Grip

- If the throttle grip does not return properly, have the throttle control system checked by an authorized Kawasaki dealer.

## Idle Speed

The idle speed inspection should be performed in accordance with the Periodic Maintenance chart.

## 150 MAINTENANCE AND ADJUSTMENT

This motorcycle is equipped with the Idle Speed Control System. If the idle speed is disturbed, inspection of the idle speed control should be done by an authorized Kawasaki dealer.

### NOTE

- *While the engine is cold, the fast idle system automatically raises the engine idle speed.*

#### Idle Speed

1 400 ±100 r/min (rpm)

## Clutch

### Clutch Operation Inspection

- Check that the clutch lever operates properly and that the inner cable slides smoothly. If there is any irregularity, have the clutch cable checked by an authorized Kawasaki dealer.

- Check the clutch lever free play.

#### Clutch Lever Free Play

2 – 3 mm (0.08 – 0.12 in.)

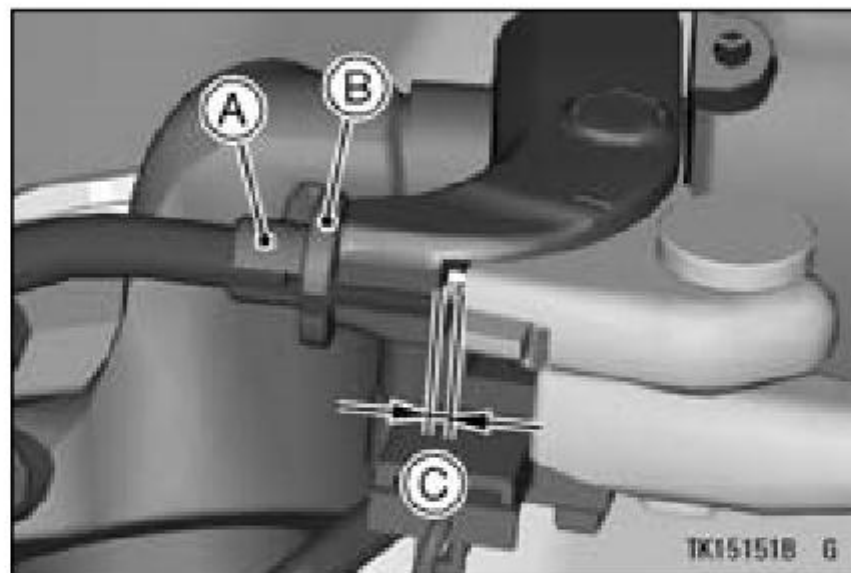

A. Adjuster

B. Locknut

C. Clutch Lever Free Play

- If the free play is incorrect, adjust the lever free play as follows.



**Clutch Lever Free Play Adjustment**

- Loosen the locknut, and turn the adjuster so that the clutch lever will have the specified free play.

**WARNING**

**Excess clutch lever free play could prevent clutch disengagement and cause a crash resulting in serious injury or death. When adjusting the clutch lever free play, be sure the upper end of the clutch outer cable is fully seated in its fitting so that it doesn't slip into place later and create excessive free play.**

- Tighten the locknut.
- If it cannot be done, have the clutch cable adjusted by an authorized Kawasaki dealer.

**NOTE**

- *After the adjustment is made, start the engine and check that the clutch does not slip and that it releases properly.*

**Drive Chain****Drive Chain Lubrication**

Lubrication is necessary after riding through rain or on wet roads, or any time that the chain appears dry.

Use a lubricant for sealed chains to prevent deterioration of chain seals. If the chain is especially dirty, clean it using a cleaner for sealed chains following the instructions supplied by the chain cleaner manufacturer.

- Apply lubricant to the sides of the rollers so that it will penetrate to the rollers and bushings. Apply lubricant to the seals so that the seals will be

## 152 MAINTENANCE AND ADJUSTMENT

coated with lubricant. Wipe off any excess lubricant.

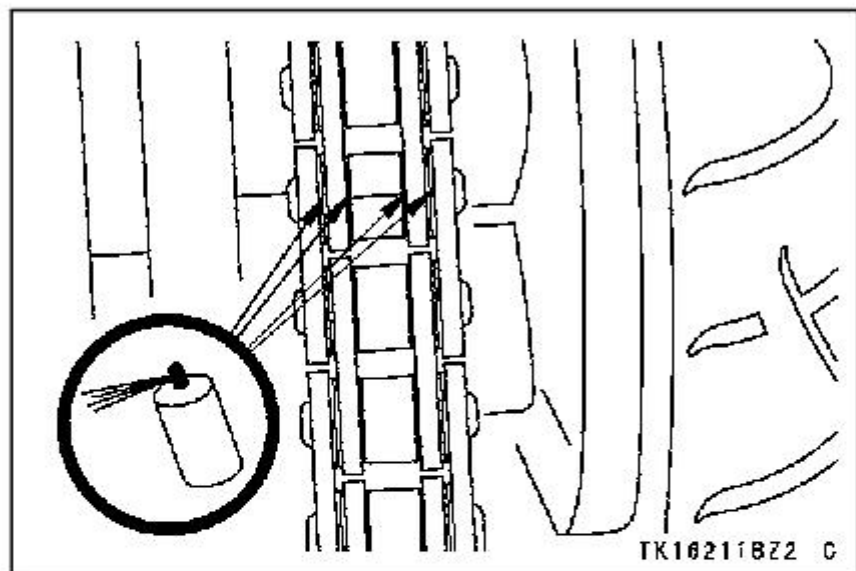

- Wipe off any lubricant that gets on the tire surface.

### ***Drive Chain Slack Inspection***

- Set the motorcycle up on its side stand.
- Clean the chain if it is dirty, and lubricate it if it appears dry.
- Rotate the rear wheel to find the position where the chain is tightest, and

measure the maximum chain slack by pulling up and pushing down the chain midway between the engine sprocket and rear wheel sprocket.

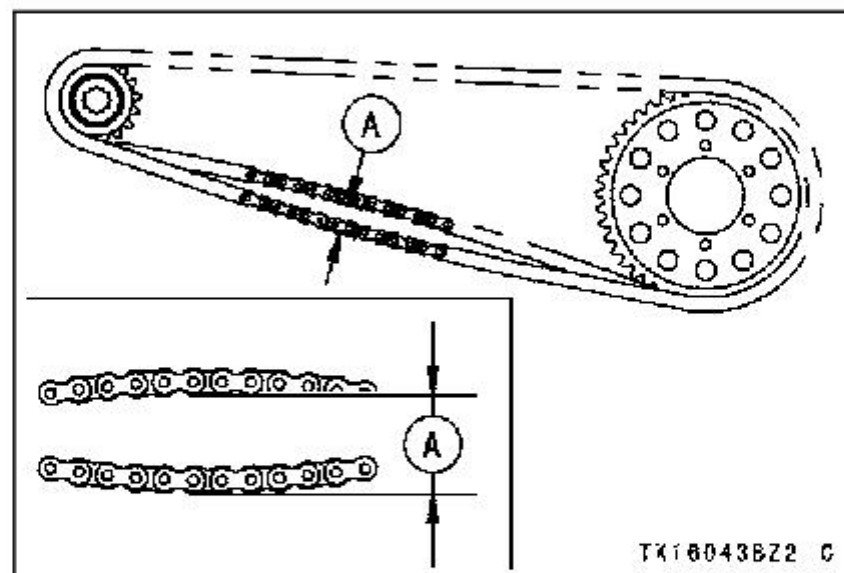

### **A. Chain Slack**

- If the drive chain is too tight or too loose, adjust it so that the chain slack is within the standard value.

### **Drive Chain Slack**

Standard: 25 – 35 mm (1.0 – 1.4 in.)

***Drive Chain Slack Adjustment***

- Remove the cap from the rear axle nut.
- Loosen the left and right chain adjuster locknuts.
- Remove the cotter pin, and loosen the axle nut.

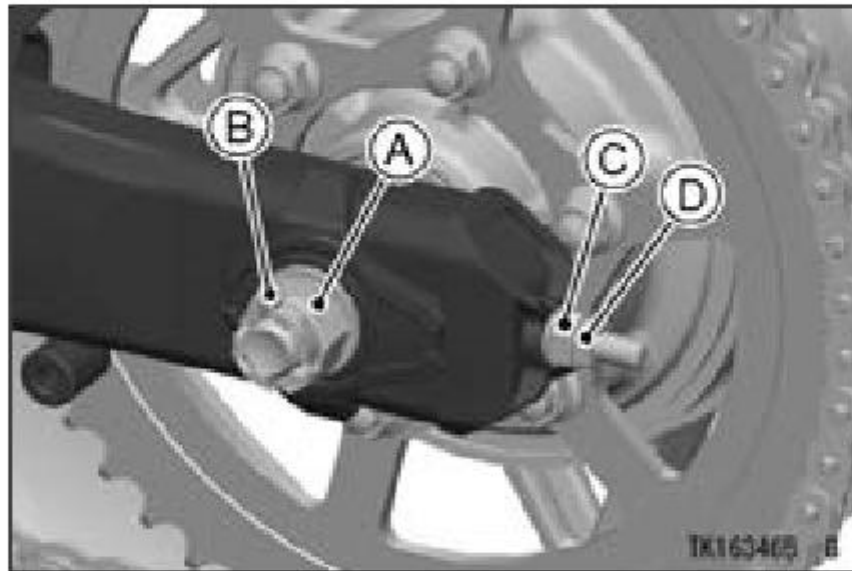

- A. Axle Nut
- B. Cotter Pin
- C. Adjuster
- D. Locknut

- If the chain is too loose or too tight, turn the left and right chain adjusters evenly to adjust the drive chain slack.
- Turn both chain adjusters evenly until the drive chain has the correct amount of slack. To keep the chain and wheel properly aligned, the left wheel alignment indicator should align with the same swingarm mark that the right wheel alignment indicator aligns with.

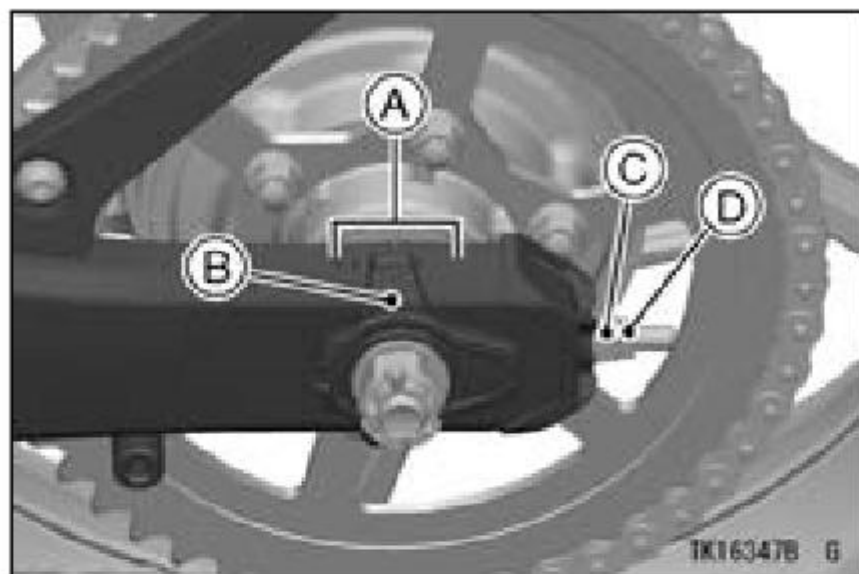

- A. Marks
- B. Wheel Alignment Indicator
- C. Adjuster
- D. Locknut

### NOTE

- *Wheel alignment can also be checked using the straightedge or string method.*

### WARNING

Misalignment of the wheel will result in abnormal wear, and may result in an unsafe riding condition. Align the rear wheel using the marks on the swingarm or measuring the distance between the center of the axle and swingarm pivot.

- Tighten both chain adjuster locknuts.
- Tighten the axle nut to the specified torque.

### Tightening Torque

Axle Nut: 98 N·m (10 kgf·m, 72 ft·lb)

### NOTE

- *If a torque wrench is not available, this item should be serviced by an authorized Kawasaki dealer.*

- Rotate the wheel, measure the chain slack again at the tightest position, and readjust if necessary.
- Install a new cotter pin through the axle nut and axle, and spread its ends.

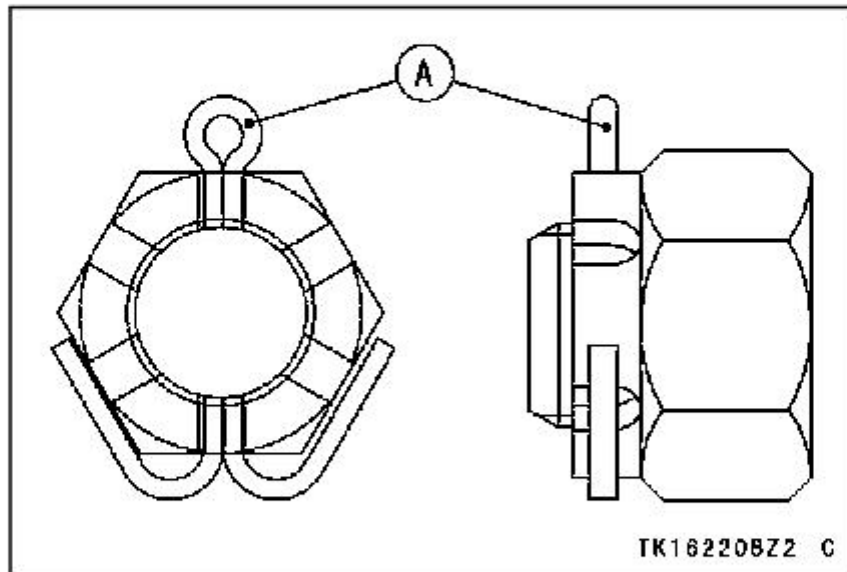

A. Cotter Pin

- *the cotter pin hole in the axle shaft, tighten the nut clockwise up to the next alignment.*
- *It should be within 30 degrees.*
- *Loosen once and tighten again when the slot goes past the nearest hole.*

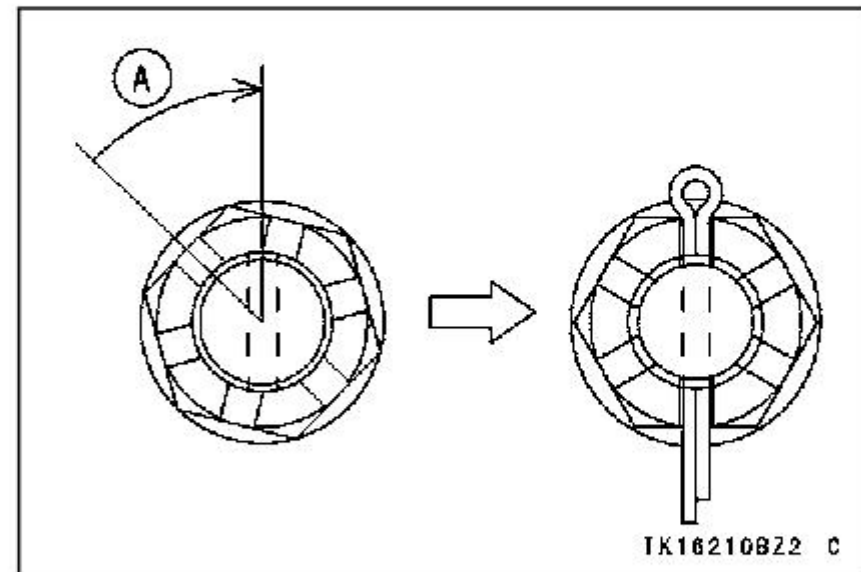

A. Turn Clockwise

**NOTE**

- *When inserting the cotter pin, if the slots in the nut do not align with*

**WARNING**

A loose axle nut can lead to an accident resulting in serious injury or death. Tighten the axle nut to the proper torque and install a new cotter pin.

- Install the cap to the rear axle nut.
- Check the rear brake (see the Brakes section).

## Brakes

If you feel there is something wrong when applying the brakes, have the brake system checked by an authorized Kawasaki dealer immediately.

**WARNING**

Air in the brake lines diminish braking performance and can cause an accident resulting in injury or death. If the brake lever or pedal feels mushy when it is applied, there might be air in the brake lines or the brake may be defective. Have the brake checked immediately by an authorized Kawasaki dealer.

### *Brake Fluid Level Inspection*

- With the front brake fluid reservoir held horizontal, the brake fluid level must be above the lower level line.

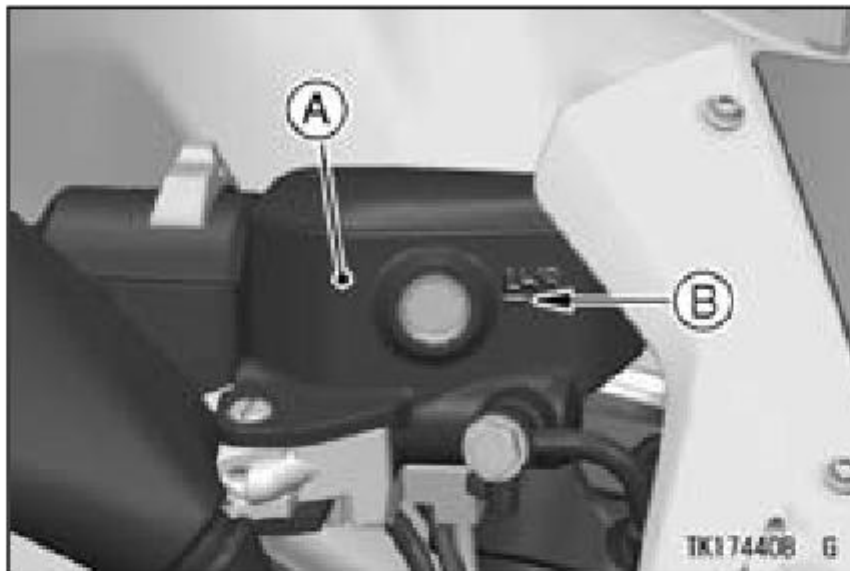

**A. Front Brake Fluid Reservoir**  
**B. Lower Level Line**

- With the rear brake fluid reservoir held horizontal, the brake fluid level must be kept between the upper and lower level lines.

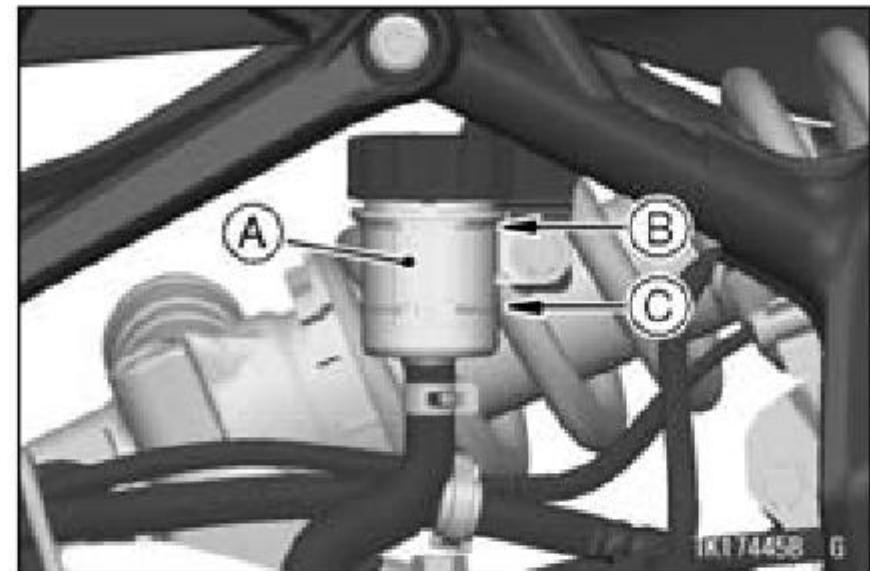

**A. Rear Brake Fluid Reservoir**  
**B. Upper Level Line**  
**C. Lower Level Line**

- If the fluid level is lower than the lower level line, it may indicate that the fluid is leaking. In this case, have the brake system inspected by an authorized Kawasaki dealer.

### ***Brake Pad Wear Inspection***

Inspect the brakes for wear. For each front and rear disc brake caliper, if the

## 158 MAINTENANCE AND ADJUSTMENT

thickness of either pad lining is less than below table, replace both pads in the caliper as a set. Pad replacement should be done by an authorized Kawasaki dealer.

### Lining Thickness Service Limit

Front	1 mm (0.04 in.)
Rear	1 mm (0.04 in.)

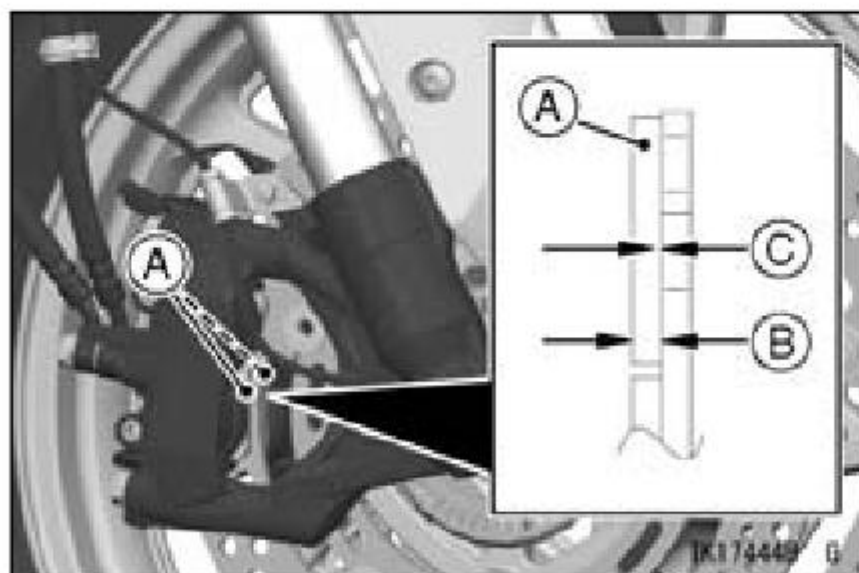

A. Front Brake Pads  
B. Lining Thickness  
C. Service Limit

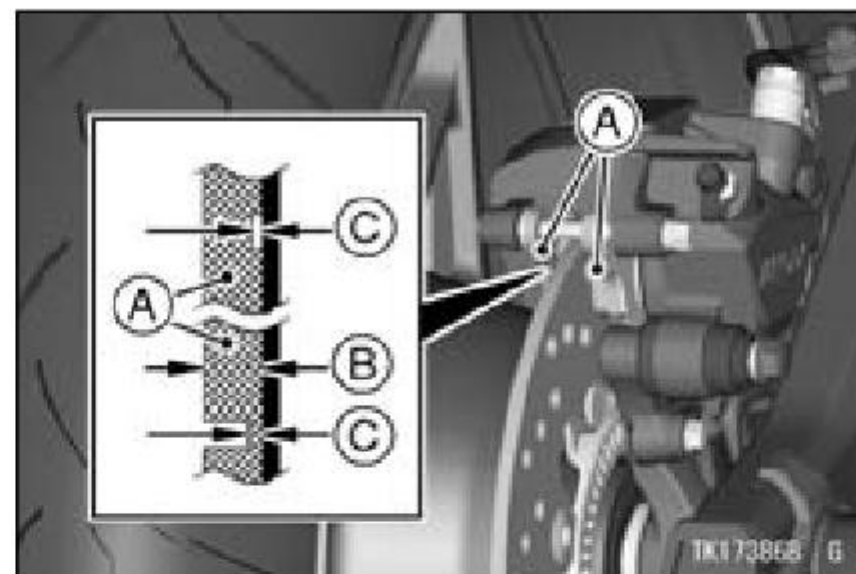

A. Rear Brake Pads  
B. Lining Thickness  
C. Service Limit

## Brake Light Switches

### *Brake Light Switch Inspection*

- Turn the ignition switch on.
- The brake light should go on when the front brake is applied.



- If it does not, ask your authorized Kawasaki dealer to inspect the front brake light switch.
- Check the operation of the rear brake light switch by depressing the brake pedal. The brake light should go on after the proper pedal travel.

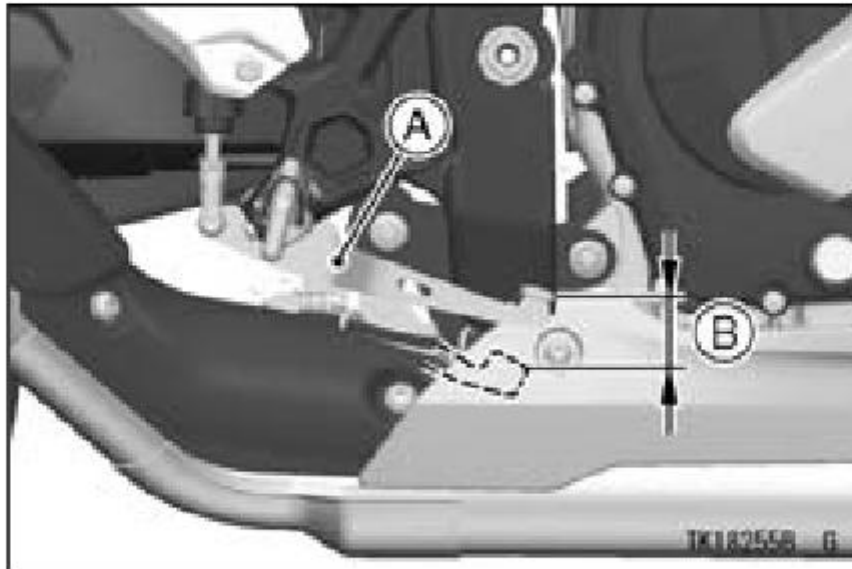

**A. Brake Pedal**  
**B. Brake Pedal Travel**

- If the light does not come on, adjust the rear brake light switch.

### Brake Pedal Travel

7 mm (0.28 in.)

### Brake Light Switch Adjustment

- To adjust the rear brake light switch, move the switch up or down by turning the adjusting nut.

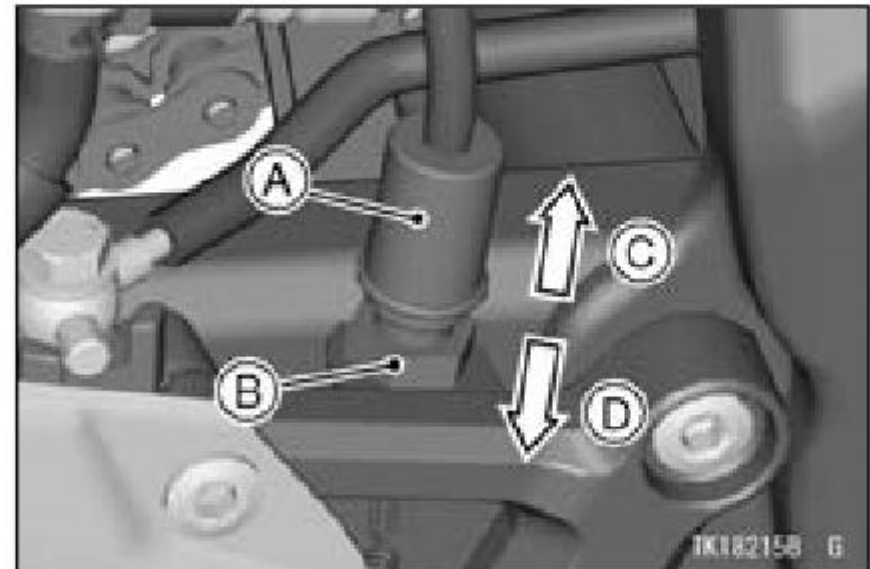

**A. Rear Brake Light Switch**  
**B. Adjusting Nut**  
**C. Lights sooner**  
**D. Lights later**

***NOTICE***

To avoid damaging the electrical connections inside the switch, be sure that the switch body does not turn during adjustment.

**Suspension System**

**Front Fork**

***NOTICE***

After riding on the normal road, the unpaved road and in the rainy weather, clean off any dirt (grit, mud or insect etc.) that stuck to inner tube before it hardens. If the motorcycle keeps running with the dirt stuck to the inner tube, the oil seal will be damaged and it causes the oil leak.

***Spring Preload Adjustment***

The adjuster is located at the top of right front fork leg.

- Turn the adjuster clockwise to increase spring preload and stiffen the suspension.
- Turn the adjuster counterclockwise to decrease preload and soften the suspension.

### **NOTICE**

**Do not turn the adjuster beyond the fully seated position or the adjusting mechanism may be damaged.**

### **NOTE**

- *The spring preload adjuster can be turned with the allen wrench or suitable tool.*
- *The standard and setting limit are shown in the Setting Tables.*



A. Spring Preload Adjuster

## **Rear Shock Absorber**

### ***Spring Preload Adjustment***

The spring adjusting nut on the rear shock absorber can be adjusted.

If the spring action feels too soft or too stiff, have it adjusted by an authorized Kawasaki dealer.

## 162 MAINTENANCE AND ADJUSTMENT

### ***Rebound Damping Force Adjustment***

The adjuster is located at the lower end of the rear shock absorber.

- Turn the adjuster clockwise with a flat tip screwdriver to increase damping force.
- Turn the adjuster counterclockwise to decrease damping force.

### ***NOTICE***

**Do not turn the adjuster beyond the fully seated position or the adjusting mechanism may be damaged.**

### **NOTE**

- *The standard and setting limit are shown in the Setting Tables.*



**A. Rebound Damping Force Adjuster**

### ***Compression Damping Force Adjustment***

The adjuster is located at the lower end of the rear shock absorber.

- Turn the adjuster clockwise with a flat tip screwdriver to increase damping force.
- Turn the adjuster counterclockwise to decrease damping force.

**NOTICE**

Do not turn the adjuster beyond the fully seated position or the adjusting mechanism may be damaged.

**NOTE**

○ *The standard and setting limit are shown in the Setting Tables.*

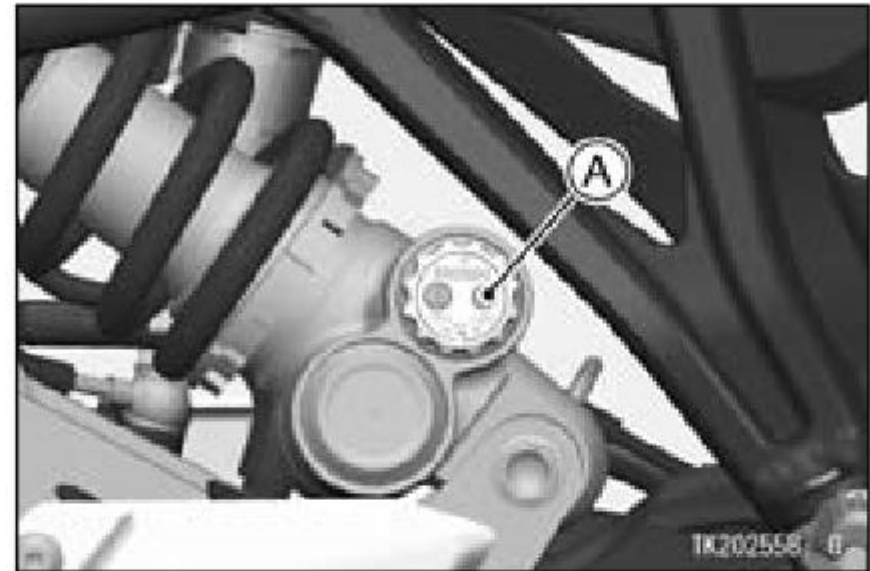

**A. Compression Damping Force Adjuster**

## Setting Tables

### Front Fork Spring Preload Setting

	Softest setting limit	<b>Standard</b>	Hardest setting limit
Adjuster Position	0*	<b>2 turns in**</b>	20 turns in**
Spring Action	Weak	←→	Strong
Setting	Soft	←→	Hard
Load	Light	←→	Heavy
Road	Good	←→	Bad
Speed	Low	←→	High

\*: This position is the fully seated position (turned fully counterclockwise).

\*\* : In from the fully seated position (turned fully counterclockwise). This adjustment range may not exactly match the number shown in the table due to small tolerance of production.

**Rear Shock Absorber Damping Force Settings**

		Softest setting limit	<b>Standard</b>	Hardest setting limit
Adjuster Position:	Rebound	4 turns out**	<b>2 turns out**</b>	0*
	Compression	4 1/2 turns out**	<b>2 1/4 turn out**</b>	0*
Damping Force		Weak	←→	Strong
Setting		Soft	←→	Hard
Load		Light	←→	Heavy
Road		Good	←→	Bad
Speed		Low	←→	High

\*: This position is the fully seated position (turned fully clockwise).

\*\* : Out from the fully seated position (turned fully clockwise). This adjustment range may not exactly match the number shown in the table due to small tolerance of production.

## Wheels

### *Tire Pressure Inspection*

- Remove the air valve cap.
- Check the tire pressure often, using an accurate gauge.
- Make sure to install the air valve cap securely.

### NOTE

- *Measure the tire pressure when the tires are cold (that is, when the motorcycle has not been ridden more than 1.6 km (1 mile) during the past 3 hours).*
- *Tire pressure is affected by changes in ambient temperature and altitude, and so the tire pressure should be checked and adjusted when your riding involves wide variations in temperature or altitude.*



**A. Tire Pressure Gauge**

### **Tire Air Pressure (when cold)**

Front	225 kPa (2.25 kgf/cm <sup>2</sup> , 32 psi)
Rear	250 kPa (2.50 kgf/cm <sup>2</sup> , 36 psi)

### **Tire Wear, Damage**

As the tire tread wears down, the tire becomes more susceptible to puncture and failure. An accepted estimate is that 90% of all tire failures occur during the last 10% of tread life (90% worn).



So it is false economy and unsafe to use the tires until they are bald.

**Tire Wear Inspection**

- Measure the depth of the tread with a depth gauge, and replace any tire that has worn down to the minimum allowable tread depth.

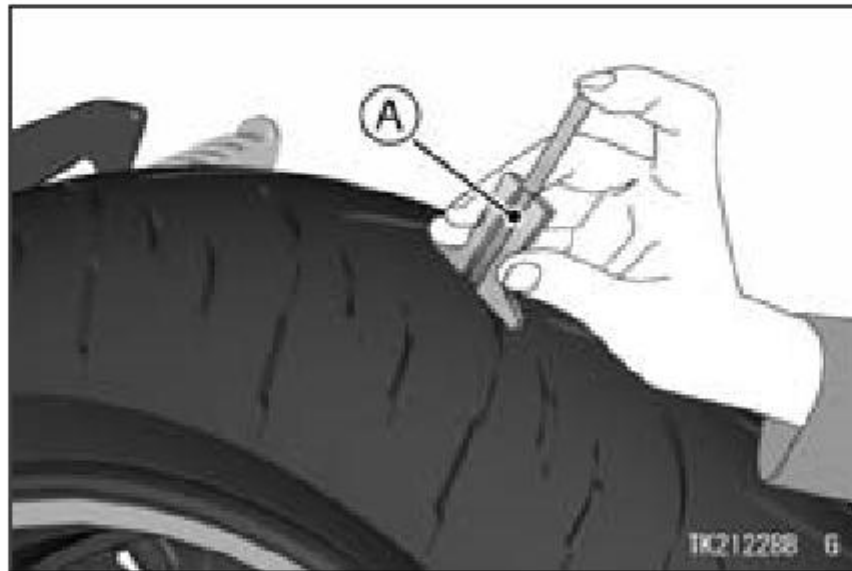

**A. Tire Depth Gauge**

**Minimum Tread Depth**

Front	–	1 mm (0.04 in.)
Rear	Under 130 km/h (80 mph)	2 mm (0.08 in.)
	Over 130 km/h (80 mph)	3 mm (0.12 in.)

- Visually inspect the tire for cracks and cuts, replacing the tire in case of bad damage. Swelling or high spots indicate internal damage, requiring tire replacement.

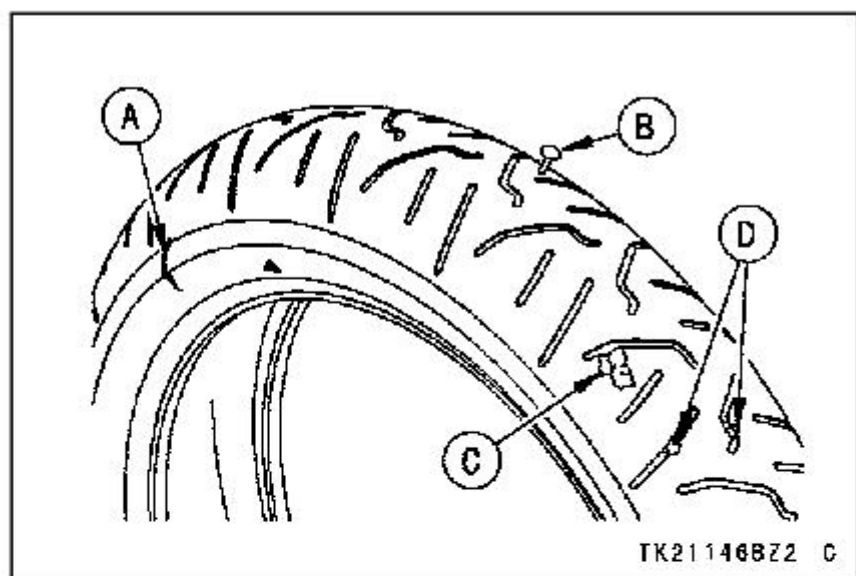

- A. Crack or Cut
- B. Nail
- C. Swelling or High Spot
- D. Stone

- Remove any imbedded stones or other foreign particles from the tread.

### NOTE

- *Have the wheel balance inspected whenever a new tire is installed.*

### ⚠ WARNING

Tires that have been punctured and repaired do not have the same capabilities as undamaged tires and can suddenly fail, causing an accident resulting in serious injury or death. Replace damaged tires as soon as possible. To ensure safe handling and stability, use only the recommended standard tires for replacement, inflated to the standard pressure. If it is necessary to ride on a repaired tire, do not exceed 100 km/h (60 mph) until the tire is replaced.

### NOTE

- *Most countries may have their own regulations requiring a minimum tire tread depth; be sure to follow them.*

- *When operating on public roadways, keep maximum speed under traffic law limits.*

**Standard Tire**

Front	<p>Make, Type: DUNLOP, SPORTMAX GPR -300F W</p> <p>Size: 120/70ZR17 M/C (58W)</p>
Rear	<p>Make, Type: DUNLOP, SPORTMAX GPR -300 W</p> <p>Size: 160/60ZR17 M/C (69W)</p>

 **WARNING**

**Mixing tire brands and types can adversely affect handling and cause an accident resulting in injury or death. Always use the same manufacturer's tires on both front and rear wheels.**

 **WARNING**

**New tires are slippery and may cause loss of control and injury. A break-in period of 160 km (100 miles) is necessary to establish normal tire traction. During break-in, avoid sudden and maximum braking and acceleration, and hard cornering.**

## Battery

The battery installed in this motorcycle is a sealed type, so it is not necessary to check the battery electrolyte level or add distilled water.

### **NOTICE**

**Never remove the sealing strip, or the battery can be damaged. Do not install a conventional battery in this motorcycle, or the electrical system cannot work properly.**

Make	Yuasa Battery
Type	YTZ10

### **Battery Maintenance**

It is the owner's responsibility to keep the battery fully charged. Failure to do

so can lead to battery failure and leave you stranded.

If you are riding your vehicle infrequently, inspect the battery voltage weekly using a voltmeter. If it drops below 12.8 volts, the battery should be charged using an appropriate charger (check with your Kawasaki dealer). If you will not be using the motorcycle for longer than two weeks, the battery should be charged using an appropriate charger. Do not use an automotive-type quick charger that may overcharge the battery and damage it.

### **NOTE**

○ *Leaving the battery connected causes the electrical components (clock etc.) to make the battery discharged, resulting the over discharge of the battery. In this case, the repair or replacement of the battery is not included in the warranty. If you do*

*not drive for four weeks or more, disconnect the battery from the vehicle.*

**Kawasaki-recommended chargers are:**

Battery Mate 150-9

OptiMate 4

Yuasa MB-2040/2060

Christie C10122S

If the above chargers are not available, use equivalent one.

For more details, ask your Kawasaki dealer.

### ***Battery Charging***

- Charge the battery following the instructions of your battery charger.
- The charger will keep the battery fully charged until you are ready to re-install the battery in the motorcycle (see Battery Installation).

## **DANGER**

**Battery acid generates hydrogen gas which is flammable and explosive under certain conditions. It is present within a battery at all times, even in a discharged condition. Keep all flames and sparks (cigarettes) away from the battery. Wear eye protection when working with a battery. In the event of battery acid contact with skin, eyes, or clothing, wash the affected areas immediately with water for at least five minutes. Seek medical attention.**

 **WARNING**

Battery posts, terminals and related accessories contain lead and lead compounds, chemicals known to the State of California to cause cancer and reproductive harm. Wash hands after handling.

***Battery Removal***

- Make sure the ignition switch is turned off.
- Remove the rider's seat (see Seats section in the GENERAL INFORMATION chapter).
- Remove the bolt and the battery holder.

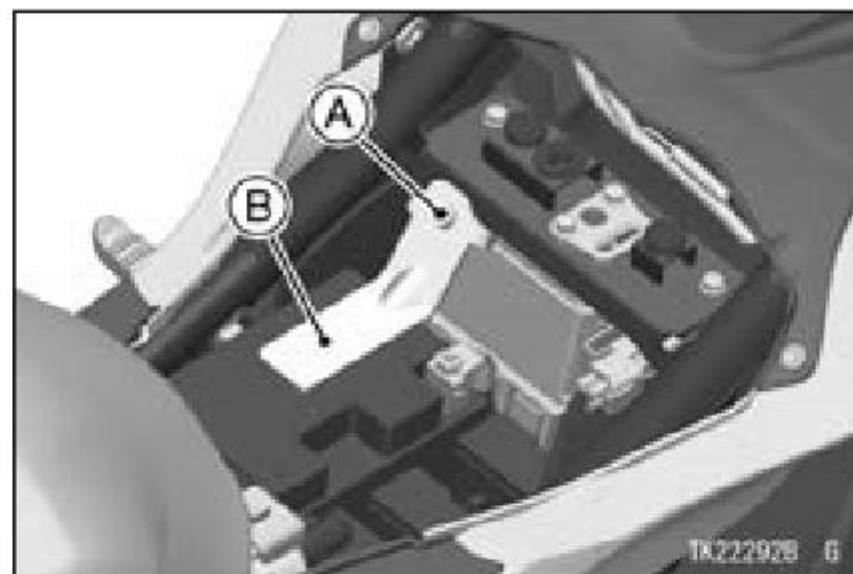

**A. Bolt**

**B. Battery Holder**

- Disconnect the negative (-) cable from the (-) terminal.
- Slide the red cap from the positive (+) terminal.
- Disconnect the positive (+) cable from the (+) terminal.

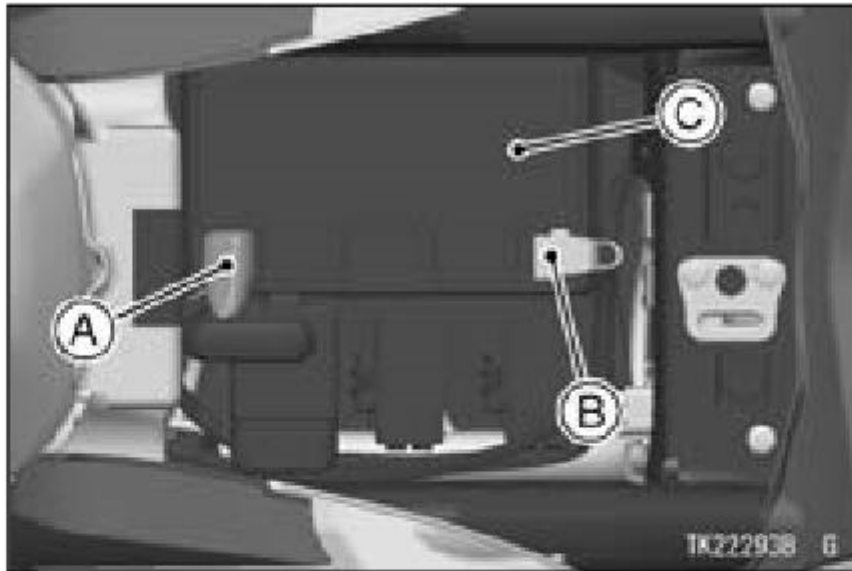

- A. Red Cap and (+) Terminal
- B. (-) Terminal
- C. Battery

- Take the battery out of the battery case.
- Clean the battery using a solution of baking soda and water. Be sure that the cable connections are clean.

### ***Battery Installation***

- Place the battery in the battery case.

- Connect the positive (+) cable to the (+) terminal, and then connect the negative (-) cable to the (-) terminal.

### **NOTE**

- *When connecting the battery negative (-) cable, be sure to tighten the terminal bolt while pressing the battery cable terminal against the battery terminal.*

### **NOTICE**

**Installing the (-) cable to the (+) terminal of the battery or the (+) cable to the (-) terminal of the battery can seriously damage the electrical system.**

- Put a light coat of grease on the terminals to prevent corrosion.
- Cover the (+) terminal with the red cap.

## 174 MAINTENANCE AND ADJUSTMENT

- Install the removed parts.

### Headlight

Headlight aiming should be done by an authorized Kawasaki dealer.

#### *Horizontal Adjustment*

The headlight beam is adjustable horizontally. If not properly adjusted horizontally, the beam will point to one side rather than straight ahead.

- Turn the horizontal adjuster in or out until the beam points straight ahead.

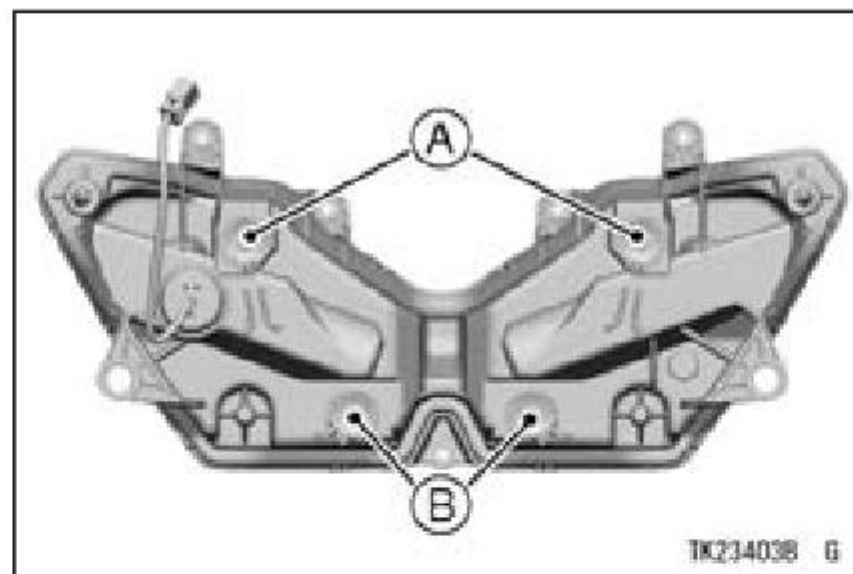

- A. Vertical Adjusters**  
**B. Horizontal Adjusters**

#### *Vertical Adjustment*

The headlight beam is adjustable vertically. If adjusted too low, neither low nor high beam will illuminate the road far enough ahead. If adjusted too high, the high beam will fail to illuminate the road close ahead, and the low beam will blind oncoming drivers.

- Turn the vertical adjuster in or out to adjust the headlight vertically.



**NOTE**

- On high beam, the brightest points should be slightly below horizontal. The proper angle is 0.4 degrees below horizontal. This is a 50 mm (2.0 in.) drop at 7.6 m (25 ft) measured from the center of the headlight, with the motorcycle on its wheels and the rider seated.

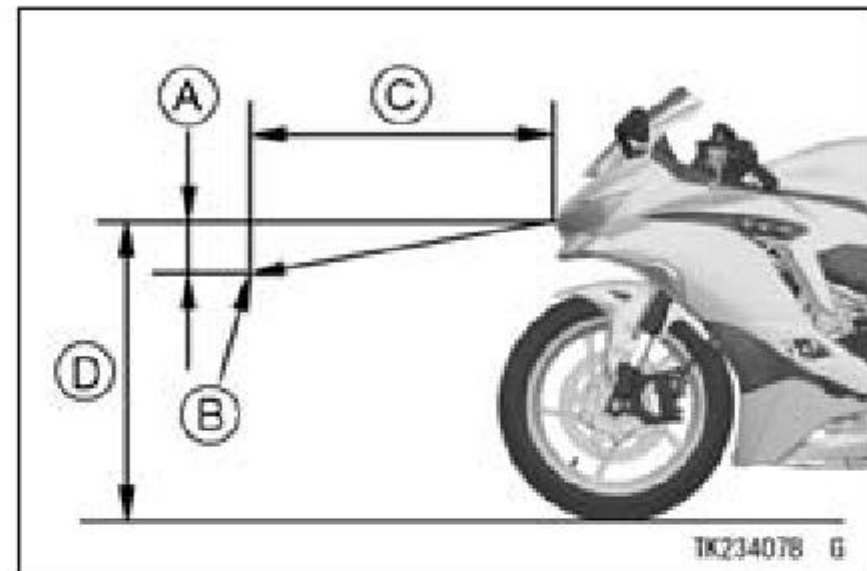

- A. 50 mm (2.0 in.)
- B. Center of Brightest Spot
- C. 7.6 m (25 ft)
- D. Height of Headlight Center

**Fuses**

Fuses are arranged in the fuse boxes located under the rider's seat. The main fuse is located under the rider's seat. If a fuse fails during operation,

## 176 MAINTENANCE AND ADJUSTMENT

inspect the electrical system to determine the cause, and then replace it with a new fuse of proper amperage.

If the fuse fails repeatedly, there is something wrong with the electrical system. Have the motorcycle checked by an authorized Kawasaki dealer.

The main fuse removal should be done by an authorized Kawasaki dealer.

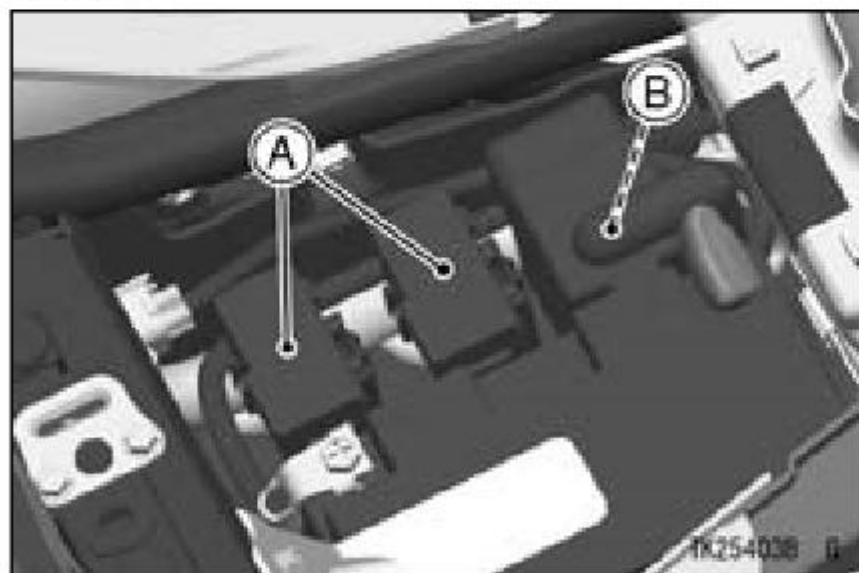

**A. Fuse Boxes**  
**B. Main Fuse**

### **WARNING**

**Substituting fuses can cause wiring to overheat, catch fire and/or fail. Do not use any substitute for the standard fuse. Replace the blown fuse with a new one of the correct capacity, as specified on the fuse boxes and main fuse.**

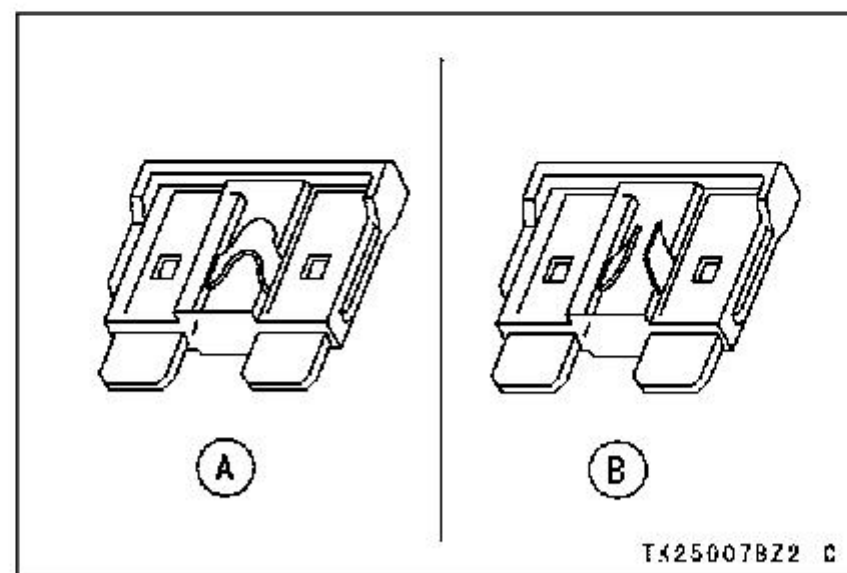

**A. Normal**  
**B. Failed**

## General Lubrication

Lubricate the points shown below, with either engine oil or regular grease, in accordance with the Periodic Maintenance Chart or whenever the vehicle has been operated under wet or rainy conditions.

Before lubricating each part, clean off any rusty spots with rust remover and wipe off any grease, oil, dirt, or grime.

### ***Apply motor oil to the following pivots***

- Side Stand
- Clutch Lever
- Front Brake Lever
- Rear Brake Pedal

### ***Lubricate the following cables with a pressure cable luber***

- (K) Clutch Inner Cables

### ***Apply grease to the following points***

- (K) Clutch Inner Cable Upper Ends

(K): Should be serviced by an authorized Kawasaki dealer.

### **NOTE**

- *After connecting the cables, adjust them.*

## Cleaning

---

### **General Precautions**

---

Frequent and proper care of your vehicle will enhance its appearance, optimize overall performance, and extend its useful life. Covering your vehicle with a high quality, breathable vehicle cover will help protect its finish from

## 178 MAINTENANCE AND ADJUSTMENT

harmful UV rays, pollutants, and reduce the amount of dust reaching its surfaces.

### **WARNING**

**Build-up of debris or flammable material in and around the vehicle chassis, engine, and exhaust can cause mechanical problems and increase the risk of fire. When operating the vehicle in conditions that allow debris or flammable material to collect in and around the vehicle, inspect the engine, electrical component and exhaust areas frequently. If debris or flammable materials have collected, park the vehicle outside and stop the engine. Allow the engine to cool, then remove any collected debris. Do not park or store the vehicle in an enclosed space prior to inspecting for build-up of debris or flammable materials.**

- Be sure the engine and exhaust are cool before washing.
- When washing the vehicle, always use a mild neutral detergent and water.
- Avoid applying all harsh chemicals, solvents, degreaser, oil remover, electrical contact cleaner, and household cleaning products such as ammonia-based window cleaners. They will damage or deteriorate painted parts, plastic parts, rubber parts and other synthetic parts including covers and headlight lens.
- Avoid applying degreaser to seals, brake pads, and tires.
- Gasoline, brake fluid, and coolant will damage the finish of painted and plastic surfaces: wash them off immediately.
- Avoid wire brushes, steel wool, and all other abrasive pads or brushes.

- Take care when washing the headlight lens and other plastic parts as they can easily be scratched.

### NOTE

- *After riding in an area where the roads are salted or near the ocean, immediately wash your vehicle with cold water. Do not use warm water as it accelerates the chemical reaction of the salt. After drying, apply a corrosion protection spray on all metal and chrome surfaces to prevent corrosion.*
- *Condensation may form on the inside of the headlight lens after riding in the rain, washing the vehicle or in humid weather. To remove the moisture, start the engine and turn on the headlight. Gradually the condensation on the inside of the lens will clear off.*

### ***Radiator***

Clean off any obstructions with a stream of low-pressure water.

#### ***NOTICE***

**Using high-pressure water, as from a car wash facility, could damage the radiator fins and impair the radiator's effectiveness. Do not obstruct or deflect airflow through the radiator by installing unauthorized accessories in front of the radiator or behind the cooling fan. Interference with the radiator airflow can lead to overheating and consequent engine damage.**

### ***Matte Paint Parts***

- When washing the vehicle, always use a mild neutral detergent and water, or cleaners for matte paint.
- The matte paint effect may be lost when the paint is excessively rubbed.
- If any doubt, consult an authorized Kawasaki dealer.

### ***Plastic Parts***

After washing, use a soft cloth to gently dry plastic parts. When dry, treat the headlight lens and other non painted plastic parts with an approved plastic cleaner/polisher product.

**NOTICE**

**Plastic parts may deteriorate and break if they come in contact with chemical substances or household cleaning products such as gasoline, brake fluid, window cleaners, thread-locking agents, or other harsh chemicals. If a plastic part comes in contact with any harsh chemical substance, wash it off immediately with water and a mild neutral detergent, and then inspect for damage. Avoid using abrasive pads or brushes to clean plastic parts, as they will damage the part's finish.**

**Chrome and Aluminum**

Chrome and uncoated aluminum parts can be treated with a chrome/aluminum polish. Coated aluminum

should be washed with a mild neutral detergent and finished with a spray polish. Aluminum wheels, both painted and unpainted can be cleaned with special non-acid based wheel spray cleaners.

**Leather, Vinyl, and Rubber**

If your vehicle has leather accessories, special care must be taken. Use a leather cleaner/treatment to clean and care for leather accessories. Washing leather parts with detergent and water will damage them, shortening their life.

Vinyl parts should be washed with the rest of the vehicle, then treated with a vinyl treatment.

The sidewalls of tires and other rubber components should be treated with a rubber protectant to help prolong their useful life.

### Where to be Careful

---

Avoid spraying water with any great force near the following places.

- Disc brake master cylinder and caliper.
- Under the rider's seat - if water gets into the fuse box or battery, it can ground out the spark. When this happens the vehicle will not operate properly and the affected parts must be wiped dry.

### **NOTICE**

Coin operated, high pressure spray washers are not recommended. Water may be forced into bearings and other components causing eventual failure from rust and corrosion. Some soaps are highly alkaline and may leave a residue or cause spotting.

### **NOTE**

- *Abrasive cleanser or high pressure washer will damage the surface finish on the bodywork.*

---

### Washing Your Vehicle

---

- Before washing, precautions must be taken to keep water off the following parts.



Muffler rear opening - cover with a plastic bag.

Ignition switch - cover the keyhole with tape.

- Rinse your vehicle with cold water from a garden hose to remove any loose dirt.
- Mix a mild neutral detergent (designed for motorcycles or automobiles) and water in a bucket. Use a soft cloth or sponge to wash your vehicle.
- After washing, rinse your vehicle thoroughly with clean water to remove any residue (residue from the

detergent can damage parts of your vehicle).

- Remove the plastic bag and tape.
- Use a soft cloth to dry your vehicle. As you dry, inspect your vehicle for chips and scratches. Do not let the water air dry as this can damage the painted surfaces.
- Carefully ride your vehicle at a slow speed and apply the brakes several times. This helps dry the brakes and restores them to normal operating performance.

---

## APPENDIX

---

### Storage

Whenever your motorcycle will not be in use for a long period, proper storage is essential.

It consists of checking and replacing missing or worn parts; lubricating parts to ensure that they do not corrode and, in general, preparing the motorcycle so that when the time comes to use it again, it will be in top condition.

See your authorized Kawasaki dealer for this service or do the following.

#### ***Preparation for Storage***

Make sure the area is well ventilated and free from any source of flame.

### **DANGER**

**Exhaust gas contains carbon monoxide, a colorless, odorless poisonous gas. Inhaling carbon monoxide can cause serious brain injury or death. DO NOT run the engine in enclosed areas. Operate only in a well-ventilated area.**

 **WARNING**

**Gasoline is extremely flammable and can be explosive under certain conditions, creating the potential for serious burns.**

- Turn the ignition key off.
- Do not smoke.
- Make sure the area is well ventilated and free from any source of flame or sparks; this includes any appliance with a pilot light.

 **WARNING**

**Gasoline is a toxic substance. Dispose of gasoline properly. Contact your local authorities for approved disposal methods.**

- Clean the entire vehicle thoroughly.
- Run the engine for about five minutes to warm the oil, shut it off, and drain the engine oil. (see Engine Oil section in the MAINTENANCE AND ADJUSTMENT chapter)

 **WARNING**

**Engine oil is a toxic substance. Dispose of used oil properly. Contact your local authorities for approved disposal methods or possible recycling.**

- Put in fresh engine oil.
- Empty the fuel from the fuel tank using a pump or syphon.
- Remove the spark plugs and add fogging oil into the combustion chambers. If the spark plugs cannot be removed, take the motorcycle to an authorized Kawasaki dealer.
- Set the motorcycle on a stand so that both wheels are raised off the ground. (If this cannot be done, put boards under the front and rear wheels to keep dampness away from the tire rubber.)
- Spray oil on all unpainted metal surfaces to prevent rusting. Avoid getting oil on rubber parts or in the brakes.
- Lubricate the drive chain and all the cables.
- Remove the battery, and store it where it will not be exposed to direct sunlight, moisture, or freezing temperatures. During storage it should be given a slow charge (one ampere or less) about once a month. Keep the battery well charged especially during cold weather.
- Tie plastic bag over the muffler to prevent moisture from entering.
- Put a cover over the motorcycle to keep dust and dirt from collecting on it.

### ***Preparation after Storage***

- Remove the plastic bag from the muffler.
- Charge the battery if necessary and install the battery in the motorcycle.
- Fill the fuel tank with fresh fuel.
- Check all the points listed in the Daily Checks section.
- Lubricate the pivots, bolts, and nuts.

## **Troubleshooting Guide**

If any warning indicators go on or blink, see the General Information for proper action. The following trouble shooting guide may also help you in case you experience any of the listed problems. If these checks don't help you to solve the situation, consult an authorised Kawasaki dealer.

If the starter turns but the engine does not start:

- Try turning the ignition key off and on again.
- Check the fuel level in the tank.
- Try refilling with fresh fuel if the vehicle has been stored for a while.
- Check the battery voltage.

If the starter does not turn:

- Check the ignition key is switched on.
- Check the engine stop switch.

## 188 APPENDIX

- Check the transmission is in neutral.
- Check the battery voltage.
- Check the battery terminals are tightly attached.
- Check the fuse.

If the engine stalls:

- Check the clutch is engaged/disengaged correctly.
- Check the side stand is up.
- Check the engine is warmed up enough.
- Check the fuel level in the tank.
- Try refilling with fresh fuel if the vehicle has been stored for a while.
- Check the idling speed is not too low.

## Your Warranty/Owner Satisfaction

Welcome to the Kawasaki family!

Congratulations on buying your Kawasaki vehicle. You've chosen a great, high-quality product with state-of-the-art features and built to Kawasaki's high standards. Your satisfaction is important to your authorized Kawasaki dealer and to Kawasaki Motors Corp., U.S.A. Here is some important information regarding your vehicle's limited warranty.

## ***Frequently Asked Questions***

### **What is a Limited Warranty?**

The most important thing to know about your warranty is that it protects you from manufacturing defects in material or workmanship during the warranty period. You can find the warranty period in the Kawasaki Limited Warranty Certificate your Kawasaki dealer provided to you at the time of sale. The warranty does not cover the cost of regularly-scheduled maintenance. The warranty also does not apply to the normal wear of items such as tires, brake pads, transmission drive belts, chains, sprockets, etc.

### **What is the Kawasaki Protection Plus?**

Much of the warranty coverage offered by the limited warranty can be extended by purchasing the Kawasaki Protection Plus (KPP). See your Kawasaki dealer or go to [Kawasaki.com](http://Kawasaki.com) for more information if you don't already have the KPP.

### **What Am I Responsible For?**

You are responsible for maintaining your vehicle according to the maintenance schedule shown in this owner's manual.

You are responsible for notifying your dealer immediately if there is a problem, and you, as the owner, will need to authorize the dealer to inspect the unit.

You will be responsible for paying for routine maintenance, including the first scheduled service. You can have the required servicing done by your Kawasaki dealer (recommended) or an equally-qualified service facility. You can also do your own maintenance work if you have the proper tools, service references, and mechanical skills. However, if a failure is found to be caused by improper servicing, it would not be covered by the limited warranty.

You may purchase a Kawasaki Service Manual and any necessary special tools directly from your Kawasaki dealer.

You will be responsible for paying for repairs needed because of an accident, to replace worn parts such as tires, chains, brakes, and for repairs needed because of a lack of maintenance, misuse or racing.

Whether you do it yourself or take your vehicle to a Kawasaki dealer, be sure to record your service in the Maintenance Record section of this Owner's Manual. Keep all receipts for the service and/or items necessary to perform the maintenance so that in the event of a failure you can document the service history.



## What Are The Dealership's Responsibilities?

Your Kawasaki dealer offers a wide range of services, parts, accessories, and information on your product and on Kawasaki.

Each dealer is independently owned and operated and is responsible for the dealership's operations, its repair, warranty, and service work, and its personnel.

Your dealer is responsible for completing the set up and pre-delivery service of your new Kawasaki vehicle. The dealership should also explain its operation, maintenance, and warranty provisions so you understand them at the time of purchase or at any other time you have questions.

The dealership is responsible for inspecting your Kawasaki vehicle if there is a failure, investigating the cause of the problem, and getting any needed authorization from Kawasaki if the repair is one that will be covered by the limited warranty. The dealership will also file all necessary paperwork. The dealership is responsible for correctly completing any necessary repairs, whether they are covered by the limited warranty or not.

## **How Do I Get Warranty Service?**

If there is a problem with your vehicle within the limited warranty period, you will need to schedule a service appointment and provide any maintenance records to an authorized Kawasaki dealer for inspection and diagnosis. You can go to any Kawasaki dealer for warranty repairs. Your Kawasaki dealer will inspect your vehicle and give you the results of the inspection. The dealer will perform the repairs at no cost to you if it is determined that the problem is covered by the warranty.

Kawasaki will work with your dealer to resolve any warranty issues. No authorization for warranty work can be given until your vehicle has been inspected by a Kawasaki dealer.

## **What if I am not Satisfied With My Warranty Service?**

If you aren't satisfied with your dealership's repair work or operations, it is best to discuss the situation with the appropriate dealership manager. If you have already done this, then contact the dealership's owner or general manager to request a review of the issue.

If you are unable to resolve a problem after consulting with the dealership management and need further assistance, contact Kawasaki Motors Corp., U.S.A. at

the address below. Please be certain to provide the model, vehicle identification number (VIN), mileage or hours of use, accessories, dates that events occurred and what action has been taken by both you and your dealer. Include the name and address of the dealership. To assist us in resolving your inquiry, please include copies of related receipts and any other pertinent information including the name of the dealership personnel with whom you have been working. Upon receipt of your correspondence, Kawasaki Motors Corp., U.S.A. will contact the dealership and work with it in resolving your problem.

### **Want to Contact Kawasaki?**

This owner's manual should answer most of your questions about your Kawasaki. Your Kawasaki dealer should either be able to answer any other questions you might have immediately or be able to find the answer for you.

Please send your correspondence to:

Consumer Services  
Kawasaki Motors Corp., U.S.A.  
P.O. Box 25252  
Santa Ana, CA 92799-5252  
(949) 460-5688

## Reporting Safety Defects

**(For Products Sold in the United States of America, District of Columbia, and U.S. Territories Only)**

If you believe that your vehicle has a defect which could cause a crash or could cause injury or death, you should immediately inform the National Highway Traffic Safety Administration (NHTSA) in addition to notifying Kawasaki Motors Corporation, U.S.A.

If NHTSA receives similar complaints, it may open an investigation, and if it finds that a safety defect exists in a group of vehicles, it may order a recall and remedy campaign. However, NHTSA cannot become involved in individual problems between you, your dealer, or Kawasaki Motors Corporation, U.S.A.

To contact NHTSA, you may either call the Auto Safety Hotline toll-free at 1-800-424-9393 (or 366-0123 in Washington, D.C. area) or write to: NHTSA, U.S. Department of Transportation, Washington, D.C. 20590. You can also obtain other information about motor vehicle safety from the Hotline.

## Environmental Protection

To help preserve the environment, properly discard used batteries, tires, oils and fluids, or other vehicle components that you might dispose of in the future. Consult your authorized Kawasaki dealer or local environmental waste agency for their proper disposal procedure. This also applies to disposal of the entire vehicle at the end of its life.

## Location of DFI System Diagnostic Connector

The DFI system diagnostic connector is located under the passenger's seat lock bracket.

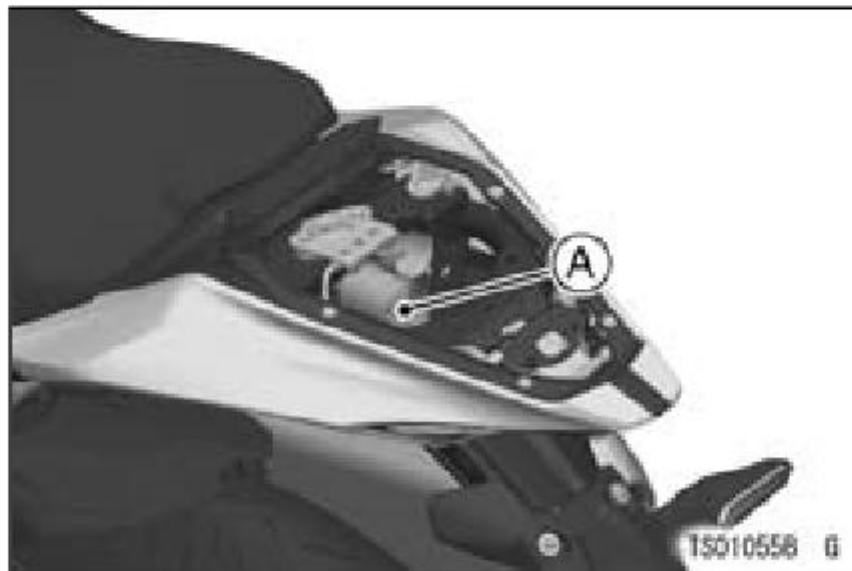

**A. DFI System Diagnostic Connector**

## Vehicle Data Recordings

This vehicle's ECU stores certain data to assist in problem diagnosis, and for other purposes such as periodic technical inspection, regulatory compliance, and research and development.

Although the recorded data varies according to the vehicle model and region, the main information types are as follows:

- Data about the vehicle's status and settings.
- Performance of the engine and electric control equipment on the engine and chassis.
- Information related to the fuel injection system and emissions.

The vehicle's ECU does not record conversations or images.

This data can only be collected when the Kawasaki special diagnostic tool is connected to the vehicle, such as when maintenance checks or other service procedures are performed.

The acquired information will not be disclosed to a third party except in following cases:

- With the consent of the vehicle owner or user
- In case of a legal request by a government agency or judicial body

- For various research purposes using processed information that do not identify the vehicle owner, user, or individual vehicle.

## Event Data Recorder

In common with many other vehicle manufacturers, Kawasaki has equipped this motorcycle with an event data recorder (EDR). The purpose of this device is to record data that assists with understanding of how some of the vehicle's systems were performing during a short period of time immediately before and during an accident or similar event involving minor damage. Due to accident variables, all vehicle performance data may not be stored on the EDR.

### NOTE

- *During normal riding, data is recorded but not saved unless the vehicle is involved in an accident event.*
- *At no time other than in the event of an accident or similar event involving minor damage is it possible for EDR data to be stored for retrieval.*
- *Depending on the type of accident event, it is possible that the EDR may not record some or all of the data, or it may not record if the EDR is damaged.*
- *This device does not collect or store personal data or information (e.g. name, gender, age).*

## 198 APPENDIX

The EDR in this vehicle is designed to record only data that is relevant to the vehicle's running condition at the time of an accident like, but not limited to, vehicle speed, engine crankshaft rotational speed and throttle opening, etc.

This data can help provide a better understanding for both the rider and the manufacturer of how the vehicle was performing at the time of an accident or near accident-like situation.

To access information on an EDR, special equipment and access to the EDR is required. Kawasaki will not share EDR information without obtaining your consent, unless required by government authorities, or acting pursuant to lawful authority.



**MAINTENANCE RECORD**

**Owner Name**.....

**Address** .....

**Phone Number** .....

**Engine Number** .....

**Vehicle Number**.....

**Key Code** .....

**Selling Dealer Name** .....

**Phone Number** .....

**Warranty Start Date** .....

**Note:** Keep this information and a spare key in a secure location.

Date	Odometer Reading	Maintenance Performed	Dealer Name	Dealer Address



**MAINTENANCE RECORD 201**

<b>Date</b>	<b>Odometer Reading</b>	<b>Maintenance Performed</b>	<b>Dealer Name</b>	<b>Dealer Address</b>





**MAINTENANCE RECORD 203**

<b>Date</b>	<b>Odometer Reading</b>	<b>Maintenance Performed</b>	<b>Dealer Name</b>	<b>Dealer Address</b>







**ZX400SP**

Kawasaki Motors, Ltd.



Printed in Thailand

GB